

## TP CENTRAL ODISHA DISTRIBUTION LIMITED

Format No. –  
Revision No. –  
Eff. Date –

### CORRIGENDUM – 01

**Tender Enquiry No.: TPCODL/ P&S/ 1000008523/ 25-26**

**Tender for “01 YEAR RC FOR SUPPLY OF 11KV,33KV METERING CUBICLE”.**

**Subject: *Regarding revision of 1.3 Calendar event & updated Technical specification with GTP of 11 V & 33KV metering cubicle & checklist to be submitted by bidder as below.***

1. Calendar of Events stands modified as stated below:

(b)	Date by which Interested and Eligible Bidder to pay Tender Fee and confirm participation as mentioned in “Procedure to Participate in Tender”	18.03.2026, 17:00 Hrs
(c)	Date & Time of Pre-Bid Meeting (If any)	(WILL BE INTIMATE IN MAIL)
(d)	Last Date and time of receipt of pre-bid queries, if any	19.03.2026 up to 15:00 Hours
(e)	Last Date of Posting Consolidated replies to all the pre-bid queries as received	21.03.2026
(f)	Last date and time of receipt of Bids	26.03.2026 up to 15:00 Hours
(g)	Date & Time of opening technical bids & EMD (Envelope-1 & 2)	Participating Bidders will get mail intimation from TPCODL E-Tender system (Ariba) when their Technical Bids are opened. Refer Section 4.2 for details
(h)	Date & Time of opening of Price of qualified bids	Bidders will get mail intimation from TPCODL E-Tender system (Ariba) when their Price Bids are opened (Refer Section 4.5)

All other terms and conditions of the original tender shall remain unaltered.

**Dated: 13.03.2026**

**Yours faithfully,  
-sd-  
HEAD - TPCODL**

Contracts Office : 1<sup>st</sup> Floor, Anuj Building, Plot No. 29, Satya Nagar,  
Bhubaneswar – 751007.

Corporate Office : TP **CENTRAL** ODISHA DISTRIBUTION LIMITED ,  
(A Joint Venture of Tata Power and Government of Odisha)

Registered Office/Corporate Office: Power House Square, Unit-8, Bhubaneswar, 751012, Tel: 0674-2541575 Web:  
[www.tpcentralodisha.com](http://www.tpcentralodisha.com), E-mail: [tpcodl@tpcentralodisha.com](mailto:tpcodl@tpcentralodisha.com), CIN: U40109OR2020 PLC032901 **Page 1 of 1**

## CONTENTS

1. SCOPE
2. APPLICABLE STANDARDS
3. CLIMATIC CONDITIONS OF INSTALLATION
4. GENERAL TECHNICAL REQUIREMENTS
5. GENERAL CONSTRUCTION
6. NAME PLATE AND MARKING
7. TESTS
8. TYPE TEST CERTIFICATES
9. PRE-DISPATCH INSPECTION
10. INSPECTION AFTER RECEIPT AT STORES
11. GUARANTEE
12. PACKING
13. TENDER SAMPLE
14. TRAINING
15. QUALITY CONTROL
16. MINIMUM TESTING FACILITIES
17. MANUFACTURING ACTIVITIES
18. SPARES, ACCESSORIES AND TOOLS
19. DRAWINGS AND DOCUMENTS
20. GUARANTEED TECHNICAL PARTICULARS
21. SCHEDULE OF DEVIATIONS

**1. SCOPE:**

The specification covers the design, manufacture, testing and supply of 33kV Indoor as well as Outdoor Type Metering cubicle & resin cast CT & PT for metering cubicle made of GI Sheet with Powder Coating.

- The metering Cubicle shall be totally enclosed, air insulated dust and vermin proof having two separate compartments HT (lower) & LT (upper) provided with two separate doors, hinged inside the box. The 33kV metering cubicle shall comply with the requirements of Indian Electricity Rule 1956 & as per relevant IS.
- The metering cubicle shall be supplied with 3nos. of 33kV single phase epoxy resin cast CT's & 3nos. of 33kV epoxy resin cast PT's and suitable clamping arrangement for holding 33kV incoming and outgoing cables and holding CTs & PTs.
- All the equipment shall comply with the requirement of relevant IS specification.

**2. APPLICABLE STANDARDS:**

Except where modified by this specification the component parts of the equipment shall comply with the following IS available (the latest versions).

- Specification for Instrument Transformers : IS 16227 (Part-1 to 4)
- HV Porcelain Bushing :IS 2099
- Galvanization: IS 2633
- Primary Terminals : IS 10601
- Hollow Pressurized and Unpressurized Ceramic and Glass Insulators for Use in Electrical Equipment with Rated Voltages Greater Than 1 000 V : IS/IEC 62155 ( IEC 62155)
- Insulated Bushings for Alternating Voltages above 1 000 V : IS/IEC 60137
- Electrical Insulation-thermal Evaluation and Designation : IS 1271 ( IEC 60085)
- Electric Power Connectors- Specification : IS 5561
- General requirements - Enamelled round copper wire : IEC 60137-0-1
- Degrees of protection provided by enclosures (IP code) : IEC 60529
- Specification for instrument Transformer : IEC 61869

**3. CLIMATIC CONDITIONS OF THE INSTALLATION:**

1	Maximum ambient temperature	55 deg C
2	Max. Daily average ambient temp	45 deg C
3	Min Ambient Temperature	0 deg C
4	Maximum Humidity	95%
5	Average Annual Rainfall	150cm
6	Average No. of rainy days per annum	120
7	Altitude above MSL not exceeding	1000m
8	Wind Pressure	300 Km/hr
9	Earthquakes of an intensity in horizontal direction	Equivalent acceleration of 0.3g
10	Earthquakes of an intensity in vertical direction	Equivalent to seismic acceleration of 0.15g (g being acceleration due to gravity)

TPCODL service area has **heavy saline conditions along the coast and High cyclonic Intensity winds with speed up to 300 Km ph.** The atmosphere is generally laden with mild acid and dust in suspension during the dry months and is subjected to fog in cold months.

#### 4. GENERAL TECHNICAL REQUIREMENT:

##### METERING CUBICLE:

Sr. No.	Particulars	Parameters
1	Normal system voltage (kV r.m.s)	33
2	Highest system voltage (kV r.m.s)	36
3	Frequency	50HZ
4	Number of Phases	3
5	Impulse withstand voltage (KVpeak) (on assembled CT-PT set)	170 KVpeak
6	Power frequency dry withstand test on (a) primary winding (b) secondary winding	70kV (rms) 3kV (rms)
7	Maximum temperature rise over maximum ambient temperature of 45°C at rated continuous thermal current at rated frequency and with rated burden.	110°C (As per IS 16227-1 for Class F Insulation)
8	Cable connection terminal of CT to base plate distance	950mm Minimum
9	Paint (Powder Coating)	RAL 7032
10	Powder Coating Thickness	80 microns
11	Rating/Size of Bus Bar	Tinned Electrolytic Copper Bus Bar size suitable for all rating of metering cubicle shall be 600A
11.a	Maximum Current Density of Copper Bus Bar	1.75 A/sqmm
12	Enclosure	
a.	Material and thickness of the meter box	3mm GI Sheet with Powder Coating, min. thickness of powder coating shall be 80micron. The paint should sustain for harsh environment & saline weather, Corrosion Protection for Panel entire life cycle (minimum 10 yrs).
b.	Non-current carrying nuts, bolts, screws etc. on enclosure	SS 304
c.	Protection against penetration of dust and water	IP 55
d.	Door of metering compartment	Wire Mess & Door of metering compartment
e.	Size of Enclosure (max. allowed)	2400mm (Height) X 1400mm (Length) X 1600mm (Depth) and

		suitable to inhouse upto CTR 600/5A
f.	Outdoor Application, if required	Suitable Canopy will be provided in outdoor application, so that meters can be viewed properly
g.	System Earthing	Suitable for 25kA/1sec
h.	Size of Earth Bus Bar	25x3mm Copper (This copper bus to be connected to both side M16 Earth Bolt)
i.	Washers and connectors	Bi-metallic washer and tinned copper connector
j.	Cable cleat	HDPE/Nylon Fire retardant cable cleat
k.	Incoming & Outgoing Cable Cleating Arrangement	Suitable for 3Cx400 sqmm and 1Cx630 sqmm (Actual size of cable to be provided during drawing approval stage)

**CURRENT TRANSFORMERS:**

There shall be three number single core single ratio dry type epoxy resin cast, current transformers conforming to IS/IEC latest amendments thereof as per details mentioned below:-

Sr. No.	Particulars	Parameters
1	Normal system voltage (kV r.m.s)	33
2	Highest system voltage (kV r.m.s)	36
3	Frequency	50HZ
4	Type	Single Phase Indoor Resin Cast
5	Number of CT	3Nos
6	Rated output (VA burden)	10VA.
7	Rated continuous thermal current	1.2 times of rated primary current
8	Short time current rating for 1 sec.	<ul style="list-style-type: none"> <li>30/5A CT Ratio to 75/5A CT Ratio – 13.1kA/1sec</li> <li>100/5 CT Ratio upto 600/5A - 25kA/1sec</li> </ul>
9	Rated dynamic current (Peak)	2.5 times of short time thermal current rating
10	Instrument security factor	≤ 5
11	Impulse withstand voltage (KVpeak) (on assembled CT-PT set)	170 KVpeak
12	Maximum temperature rise over maximum ambient temperature of 45°C at rated continuous thermal current at rated frequency and with rated burden.	110°C (As per IS 16227-1 for Class F Insulation)
13	Type of Insulation	

13.1	Impregnation	Class H vacuum pressure impregnation
13.b	Varnish on CT-PT windings	Class H varnish
13.c	Epoxy resin casting	Class F Resin
14	Limits of current (ratio) Error and phase Displacement. (For 0.2S Accuracy class)	Within limited of IS:16227 with latest amendment/revision
15	Max. ratio error	Within limited of IS:16227 with latest amendment/revision
16	Max. phase angle error	Within limited of IS:16227 with latest amendment/revision
17	System condition	Effectively earthed system
18	Thickness of base plate	5mm, Plate shall be properly with earthing arrangement
19	Type	Dry type epoxy resin cast
20	Creepage distance	900mm (It is only applicable for Insulator connecting for CT, PT & Cable Compartment, if used)
21	Transformation ratio/ CT ratio	As per above schedule of requirement.
22	No. of cores	1 Nos
23	Rated continuous thermal current temperature rise over ambient	As per IS 16227 latest amendment/revision
24	One minute power frequency voltage withstand test on secondary winding	3kV
25	Class of accuracy	0.2S
26	Secondary termination	S1 & S2 shall be clearly marked
27	CT primary current	Shall be as per tender (30A, 50A, 75A, 100A, 150A, 200A, 300A, 400A, 600A)
28	CT secondary current	5A
29	Total weight of the core before casting of Resin	To be provided by Bidder
30	Total weight of the unit after casting of Resin	To be provided by Bidder
31	Power frequency dry withstand test on (c) primary winding (d) secondary winding	70kV (rms) 3kV (rms)
32	Washers and connectors	Bi-metallic washer and tinned copper connector
33	CT terminal shape	L-shaped or cross flat type
34	Rating/Size of Bus Bar	Tinned Electrolytic Copper Bus Bar size suitable for all rating of metering cubicle shall be 600A

**N.B.** - The dimension of the CT base plate should be **360mm** length from hole to hole and **170mm** width from hole to hole. The base plate should have open slot arrangement for adjustable fixing. Plate should be properly with earthing arrangement.

#### POTENTIAL TRANSFORMERS:

Details specification as per IS/IEC with latest amendments.

Sr. No.	Particulars	Parameters
1	Normal system voltage (kV r.m.s)	33
2	Highest system voltage (kV r.m.s)	36
3	Frequency	50HZ
4	Type	Single Phase Indoor Resin Cast
5	Number of phases	Single phase
6	No of PT	3 Nos
7	Rated Output (VA) Burden	30VA
8	Transformation ratio (PT ratio)	33KV/ $\sqrt{3}$ / 110V/ $\sqrt{3}$
9	Impulse withstand voltage (KV peak) (on assembled CT PT set)	170
10	One minute power frequency dry withstand voltage (on assembled CT-PT set) (a) Primary (KV rms) (b) Secondary (KV rms)	70kV 3kV
11	Class of accuracy	0.2
12	Rated voltage factor and time	1.2 times continuous and 1.5 times for 30 sec
17	System condition	Effectively earthed system
18	Maximum temperature raise over maximum ambient temperature (which may be taken as 45°C) at rated frequency and with rated Burden	Within limited of IS: 16227 with latest amendment/ revision.
19	Maximum ratio error	Within limited of IS: 16227 with latest amendment/ revision.
20	Maximum phase angle error	Within limited of IS: 16227 with latest amendment/ revision.
21	Type of Insulation	
21.a	Impregnation	Class H vacuum pressure impregnation
21.b	Varnish on CT-PT windings	Class H varnish
21.c	Epoxy resin casting	Class F Resin
22	Creepage distance	900mm (It is only applicable for Insulator connecting for CT, PT & Cable Compartment, if used)
21	Basic insulation Level	36/70/170 KV

22	Thickness of baseplate	5mm, Plate shall be properly with earthing arrangement.
23	Material of Bushings	Epoxy
24	Material for Rod of Bushings	Copper (if Applicable)

**N.B.-** The dimension of the PT base plate should be **280mm** length from hole to hole and **250mm** width from hole to hole (the hole is slotted). The base plate should have open slot arrangement for adjustable fixing, with proper earthing arrangement diagonally.

## 5. GENERAL CONSTRUCTION:

The 33KV metering cubicle panel shall be fabricated with 3mm GI sheet. The overall dimensions of the cubicle shall be 2400mm (Height) X 1400mm (Length) X 1600mm (Depth) and it shall be suitable for 600A CT Ratio and Busbar. Total height including base channel will be 1900mm. Height of panel is fixed. Dimension of width & depth may be increased suitably to accommodate CTs/PTs, if required. These dimensions may vary slightly as per design of manufacturer taking into care the minimum clearance of 320mm between phases as well as between phase and earth. Space for installation of energy meter should be modified to accommodate smart meter dimension (H-300 x W-200 x D-100).

- All the edges and joints shall be made and welded in such a way that no access inside the cubicle shall be possible and shall thus provide strength to robust mechanical structure both during transportation and installation.
- The metering cubicle shall be welded with 4 numbers lifting lugs of adequate strength at suitable diagonal locations for balanced lifting. All the edges and joints shall be made and welded in such a way so that no access inside the cubicle shall be possible through them and shall thus provide strength to robust mechanical construction both for transportation and installation for its use.
- The metering cubicle shall be totally enclosed and shall be provided with two nos. hinged door made of GI sheet which shall rest on the collar along the four sides of cubicle so that the door remain flushed with body of the cubicle.
- The hinge of the doors shall be concealed type (proper welded from inside) so as to eliminate any chance of de-hinging without causing any damage to the cubicle.
- The Metering cubicle shall be provided with MS channels support of 100mm x 50mm 5mm welded at bottom along it's length 1400mm.
- The metering cubicle shall be provided with M16 earthing bolt at two opposite sites with welding from inside the cubicle for fixing external earth during installation. Both earthing bolts at opposite ends to be interconnected by 25x3mm Copper. The bolts shall be connected internally to 25x3mm Copper earth bus which shall provide earthing to PT neutral & cable earth provision. Terminal bolts and washers used in metering cubicle shall be of stainless steel.
- Each of the supporting channel shall have two holes of 12mm of dia. suitable for foundation bolts.
- The Metering cubicle shall be provided with MS Earthing strip of size 50mm x 5mm welded at the two opposite base angles provided with welded nut of 6mm dia. welded from inside

the cubicle. The earthing strip can be connected by tightening a bolt from outside the metering cubicle at two opposite ends.

- The panel should be provided with 4nos. of lifting hooks.
- The metering cubicle shall have two separate compartments separated by GI sheet of 2.0mm thickness as given below.
- 2 nos. 60 W space heater to be provided with individual thermostat for each heater
- The heater must be kept on both corner side of the cubicle chamber with operating switch must kept outside. Thermostat shall be connected through separate MCB.
- 2 nos. Dehumidifier shall be given along with each heater circuit to arrest the humidity. (Make of dehumidifier shall be approved during drawing approval)

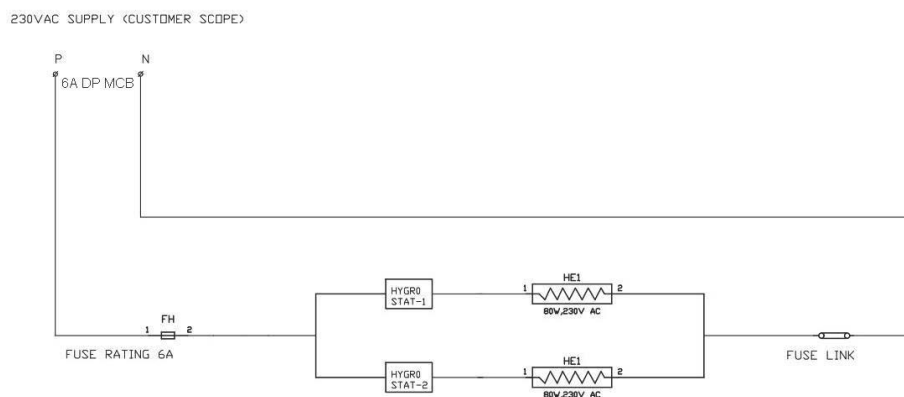

- Wire Mess to be provided on the viewing window before the toughened Glass.
- Corrosion resistant paint to be provided to avoid rusting as we are operating in saline belt.
- Secondary wiring shall be carried out with 1100V grade PVC insulated stranded copper conductor of 4.0 sq mm for CT circuit and 2.5 Sq.mm for PT and the other circuits.
- Normal current density shall not be more than 1.6 A sq mm in primary winding of the CT
- Busbar shall be made of electrical Grade copper and of suitable size to withstand the specified short circuit rating.
- HT terminals to the base plate distance shall be minimum 950mm.
- Support insulators to be provided for bus bars wherever required to provide sufficient strength
- The mounting arrangement of the CT shall be such that in-case of replacement of existing CT with higher or lower size will not require any alterations.
- 1no. 15A Switch & socket, 9W LED light with fittings shall be provided in the LT compartment

**UPPER (LT) COMPARTMENT:**

- The upper compartment of the metering cubicle shall be called LT compartment and shall have approximate height of 550mm. The compartment shall have provision for housing a tri-vector meter along with its associated wiring. The upper compartment will be one sided hinged double door type and the arrangement for meter fixing will be in inner portion.
- For fixing of KWH tri-vector meter in this compartment, four nos. MS slotted angles of suitable size shall be welded to the body from inside of partition chamber in LT compartment, two nos. slotted angles shall be bolted vertically and two nos. horizontally, which shall be movable forming to adjust the distance and height of meter to be fixed in the compartment.
- The upper compartment shall be provided with one door fabricated in one piece and hinged as per clause no. - 2.3. The door shall be provided with synthetic/semi synthetic gasket to make it dust & vermin proof. The door shall be provided with a handle and two nos. sealing arrangement. There shall be fixed (non-openable) window (approximate size 300mm x 200mm) fitted with transparent acrylic glass. The glass shall be fitted/ tightened with MS frame from inside of window. The height of the window shall be such that the reading can be taken easily from outside).
- The secondary wiring should be 4sqmm multi-strand coloured wires with Ferrules & all PT & CT secondary wires to be R Y B N colour coded.
- All wires will be colour coded (Red, Yellow, Blue, Black, Gray). The Secondary connection to be kept on front side for easy accessibility and ensure tightness.
- Earthing provision to be provided for CT Secondary Wire (S2).
- Two types of PT primary Grounding should be provided one is through strip & other through cable
- Additional non-resettable counter to be provided on door and kept on record for number of operations it is used.

**The LT compartment shall essentially contain the following:**

- Hanger of slotted angle for mounting main meter (Schneider, SECURE, HPL, GENUS make etc.) for having flexibility for mounting of meter vertically and horizontally (meter not in scope of this tender supply).

**LOWER (HT) COMPARTMENT:**

- The lower compartment of metering cubicle shall be called HT compartment and shall have approximate height of 1900mm.
- This compartment shall be housed three nos. 33KV single phase epoxy resin cast CT's for 'R', 'Y' and B' phase and three nos. 33KV single-phase epoxy resin cast PT's, connecting strip between CT's and PT's, bus bar with suitable clamping arrangement for incoming and outgoing 33KV XLPE cables. There shall be two nos. sealing arrangement diagonally in base of each CT & PT.

- The door of lower compartment shall be provided with one door fabricated in one pieces and hinged as per clause no. - 2.3 such that it becomes complete dust and vermin proof. The door shall be provided with a handle and two nos. sealing arrangement.
- The compartment should be provided with two nos. cable entries with detachable plate with brass glands of appropriate size at the bottom suitable for 33KV XLPE cable for appropriate current rating.

**The HT compartment shall be essentially contain the following:**

- 33KV epoxy resin cast CT's (single phase) - 03nos.
- 33KV/ $\sqrt{3}$ /110V/ $\sqrt{3}$  epoxy resin cast PT's (single phase) - 03nos.
- Flexible copper flat strip of 30 x 0.4mm or 8 SWG copper wire (duly insulated) to connect PT's to bus bar of CT's - 01set
- LT wiring for the secondary of CT & PT circuit, which should not less than 4 mm<sup>2</sup> copper in size - 01set
- 33KV PT primary must have 2A HT Fuse (HRC Type, Make - Bushman, Eswori, Pheonix, L&T) whereas secondary side directly connected to 3Ph 4wire Screw type front connection standard TTB (TPCODL Approved make –DAV / IMP/ Welstar) instead of coming through MCCB. Coloured Lead wires without lugs (12inches) to be provided for connection from TTB to meter.

**SEALING:**

The metering cubicles shall be completely lockable and sealable with at least one locking and two sealing arrangements of the door of each compartment. Apart from sealing arrangement of both compartments, mounting bolts of CTs and PT shall have the provisions for sealing arrangement so that removal of CTs & PTs from the installed positions in the panel (for tampering/ replacement) by the unauthorized person is not possible without breaking/ tampering the sealing arrangement. The hinge arrangement, sealing of CTs and sealing of PTs shall be diagonally arranged in the base of each CTs & PTs.

Sealing arrangement for all Doors (Front, Back and Top) of the CTPT. Sealing arrangement to be provided for meter chamber & CT/PT Chamber. Sealing arrangement to be provided on the secondary terminals (Casing type).

This sealing arrangement shall be checked by the officers at the time of checking of sample and during inspection. CT/PT secondary terminal should have a provision for sealing.

The epoxy resin casting of 33 kV CTs & PTs coils is required to be carried out under vacuum to avoid any blow holes in the casted material. To establish this Epoxy hardener and accelerator, if any is mixed in the mixing chamber under the vacuum and poured into the dyes placed in the casting chamber which is also kept under vacuum as per relevant IS specifications. The temperature as specified by the Epoxy manufacturer is maintained with thermostatic control so that all the moisture is also drained out under vacuum.

**METERING COMPARTMENT:**

- The CT secondary s1 terminal & PT secondary phase terminal of each phase shall terminate at TTB from bottom side.
- The CT secondary s2 & PT secondary neutral wires shall be wired to droppable terminal links & then to TTB.
- Make of droppable links shall be Connectwell or Elmex
- CT & PT Star formation to be made at terminal links.
- The TTB, wiring shall be carried out with source wires from CT and PT at bottom and meters wires at top. Only front connection screw type standard TTBs should be used and shall be located inside the metering panel and not on the panel door.
- TTB shall be of DAV make & Model name is SSFS.
- No lugs shall be provided for wires to meter & TTB.
- Adequate space for mounting TVM should be provided in compartment (Max dimension envisaged for Meter. Location of meter shall be at convenient height (less than five feet from ground level) for easy reading & testing purpose. Window to be provided for taking meter reading manually from outside without opening of cubicle.
- Please refer below diagram for meter wiring

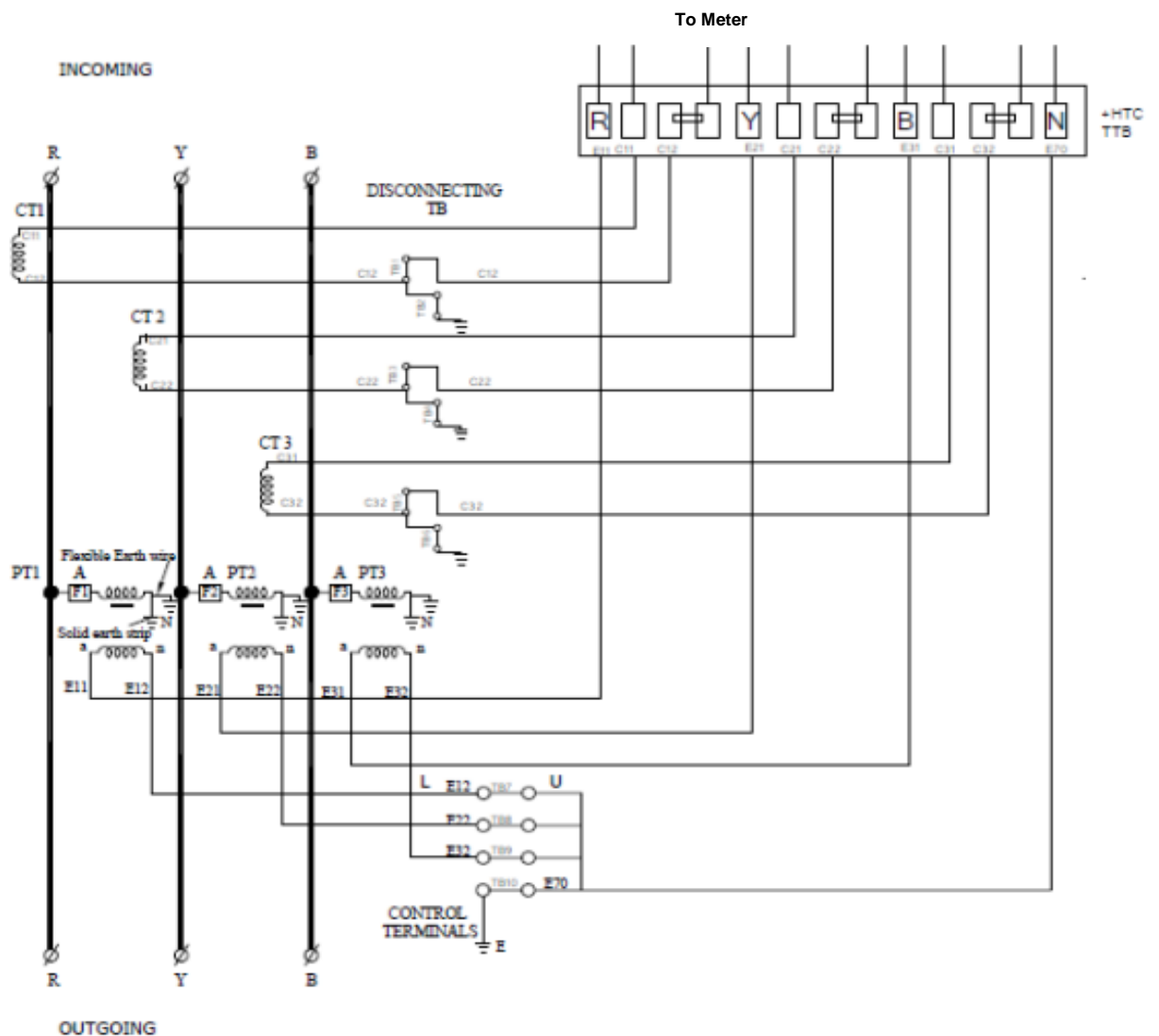

**CABLE COMPARTMENT:**

- The cable compartment shall be provided with warning on door "DANGER 33kV DO NOT OPEN THIS DOOR BEFORE SWITCH OFF THE SUPPLY".
- Suitable provision shall be made inside the compartment with proper clamping arrangement. Provision of suitable space and arrangement of proper orientation of cable termination shall be made so that there is no problem in fixing the incoming and outgoing cables. The cable size shall be 33KV, 3 core Aluminum Conductor GI Armour XLPE Insulated 400 sq.mm or 1 core Aluminum Conductor Aluminum Armour XLPE Insulated 630 sq.mm. Suitable non-magnetic cable support shall be provided on both sides for the HT cables. The CT mounting shall be made in such a way to avoid easy access or removal.
- The Incoming and outgoing marking to be done with paint on metering cubicle.

**BUSHING:**

- The metering equipment shall be supplied with adequate number of single terminals, epoxy bushings of reputed make (as approved by the Purchaser) with Brass studs as per the rating.
- The bushings shall be rated for 36 KV. The bushings shall confirm to IS: 8603 for the dimensions and IS: 5621 and IS: 2099 for other electrical requirements.

**PAINTING:**

- All paint shall be applied on clean dry surfaces under suitable atmospheric conditions by seven tank process and powder coating.
- The overall paint thickness (External & Internal) shall not be less than 80 microns.
- The paint shall not scale off or crinkle or be removed by abrasion during normal handling.
- The enclosure of the CT-PT unit shall be painted with RAL 7032 Siemens grey.

**WINDINGS & CORE:**

- Both primary and secondary winding of CT and PT must be dry type.
- Winding insulation used for PT primary must be of grade 3.
- Winding insulation used for CT primary must be of class H only.
- All windings of CT and PT must undergo vacuum pressure impregnation with varnish of reputed make suitable for withstanding maximum temperature as per Class 'H'.
- After varnish impregnation all coils to be undergo epoxy resin casting with 'F' class of reputed make. Leads shall be brought out from resin casting.
- The core material of CT-PT unit shall be of high grade non ageing electrical silicon steel (CRGO) of first quality having low hysteresis loss and high permeability to ensure accuracy at both terminal and over current voltage. The grade of the Core shall be ZDKH or better.
- The paper used for insulation shall be of high insulation grade. The insulating paper / polyester film used for insulation shall be of high insulation grade, excellent mechanical strength (tensile, tear, and stretch), high purity, chemical stability, and heat resistance. The paper density if the used shall be approx 60-190 g/m<sup>2</sup>. The insulating paper shall be used of make Weidmann or better/ polyester film shall be used of makes herztmann/ Dr. Beck/ Resin or better.
- The insulating materials for winding between HV and LV and between interlayer of the winding and for end turn shall be as per relevant IS. However, end turns have to be provided with reinforced insulation and lead connecting the bushing shall be provided with extra insulation.
- No joints shall be allowed in CT secondary wires.

- The secondary winding shall be epoxying cast and the leads shall be brought out through epoxy cast terminal.
- The wiring shall be neatly bunched together. Only 6 wires of CT and 6 wires of PT shall come out from the chamber for connections.
- Suitable size of lugs shall be used to tighten the wire with the unit's secondary terminals.
- The bus bar and HT side of PT shall be connected through a flexible copper strip or equivalent size of copper and of adequate length such that HT terminals of PTs are not subjected to any compression or tension forces.

## 6. NAME PLATE & MARKING:

An Aluminum foil plate shall be affixed on the front of cubicle to indicate the following information against which the desired information is required to be painted at site: -

- TPCODL/TPSODL/TPNODL/TPWODL property
- Manufacturer's name
- Month and Year of manufacture
- Serial number and Type designation
- Rated primary and secondary currents
- Rated frequency
- Insulation Class (F) of CT & PT
- Rated output and the corresponding accuracy class
- Highest system voltage
- Rated insulation level of primary neutral
- Rated short time thermal current
- Rated dynamic current if different than 2.5 times the rated STC rating
- Rated primary and secondary voltage
- Rated voltage factor and corresponding rated time
- Number of phases and method of connection
- Earthed or unearthed
- Guarantee period
- Reference standard
- Material code
- PO No & Date
- Panel CT ratio & accuracy class(0.2s)
- Panel PT ratio & accuracy class (0.2)
- Meter CT ratio
- Meter PT ratio
- Over all CT-PT multiplying factor
- Sanctioned load
- Date of release of connection

Warranty up to in addition to the above, one no. rating and diagram plate made of Aluminum 1mm thickness shall be provided on the front door of the HT compartment giving details viz. Serial no. of cubicle CT & PT, ratio, burden, class of accuracy, insulation class, year of manufacturing, total weight, P.O. Number and date etc.

Also, the danger plate should be shown on the front cover. Incoming and outgoing to be marked from inside of the panel (on sidewalls), and CT should be marked with P1 and P2 on the resin casting.

Following Marking on CT shall be provided (marking plate on CT shall be made of Aluminum of 1mm thickness):-

- Ratio
- Reference Standard
- Insulation Class (F)
- Burden
- Accuracy Class
- Short Time Withstand Current
- ISF
- Weight
- Serial No.
- MM/YEAR of Manufacturing
- Frequency
- System Voltage
- Basic Insulation Level (BIL)
- Manufacturer Name

Following Marking on PT shall be provided (marking plate on PT shall be made of Aluminum of 1mm thickness):-

- Ratio
- Reference Standard
- Insulation Class (F)
- Burden
- Accuracy Class
- Weight
- Serial No.
- MM/YEAR of Manufacturing
- Frequency
- System Voltage
- Basic Insulation Level (BIL)
- Manufacturer Name

Further the following shall be painted on the front with black colour and yellow background:

- Serial number
- Year of manufacture
- Ratio

## 7. TEST:

### **CALIBRATION:**

All instruments used in inspection and testing should be properly calibrated and sealed from any Govt. Test House/ Reputed Agency certified by NABL and the reports shall not be less than one year old. Calibration certifications when demanded by inspecting officers shall be provided/ produced for verification purpose.

**ROUTINE, ACCEPTANCE & TYPE TEST:**

All routine, acceptance & type tests shall be carried out separately in accordance with the relevant IS/IEC. All routine/acceptance tests shall be witnessed by the purchaser/his authorized representative. All the components shall also be type tested as per the relevant standards.

**Stage Inspection:** The manufacturer should have the facility to show the stage inspection i.e. during the period of FAT.

01 no. of Sample from any Cubicle will be completely destroyed in the bidder's laboratory in order to check the quality of resin, measurement of core weight, quality of copper used for winding and HV test will be applied for minimum 5 minutes to check the insulation level and the cost for the testing will be borne by the manufacturer

**ROUTINE & ACCEPTANCE TESTS:****CURRENT TRANSFORMERS:**

- Verification of terminal marking and polarity.
- High voltage power frequency test on Primary winding
- High voltage power frequency test on Secondary winding
- Over voltage inter-turn test.
- Determination of errors according to the requirement of accuracy class (0.2s)
- Partial discharge test in accordance with IS: 11322/1985

**POTENTIAL TRANSFORMER:**

- Verification of terminal marking and polarity.
- Power frequency dry withstand test on Primary
- Power frequency withstand test on Secondary
- Determination of errors according to the requirement of accuracy class (0.2)
- Partial discharge test measurement test in accordance with IS: 11322/1985.

**TYPE TESTS :**

The following shall constitute the type tests as per relevant IS:

**CURRENT TRANSFORMERS:**

Test Details	Type Test To be Conducted on Individual CTs	Remarks
Short-time current tests	1. STC Conducted on 30/5A CTR with 13.1kA/1sec 2. STC Conducted on 100/5A CTR with 25kA/1sec	1. STC Type Test done on 30/5A CTR will be applicable upto 75/5A CTR 2. STC Type Test done on 100/5A CTR will be applicable upto 600/5A CTR
Temperature-rise test	1. Type Test Conducted on 75/5A CTR 2. Type Test Conducted on 600/5A CTR	1. Type Test done on 75/5A CTR will be valid for lower CT Ratios (30/5A & 50/5A) 2. Type Test done on
Lightning impulse test		
Power frequency withstand test		

Determination of errors according to the requirement of accuracy class.		600/5A CTR will be valid for lower CT Ratios (600/5A, 400/5A, 300/5A, 200/5, 150/5 & 100/5A)
Instrument Security Current Test		

**POTENTIAL TRANSFORMERS:**

- Temperature-rise test
- Lightning impulse test
- Power frequency withstand test
- Determination of errors according to the requirement of accuracy class.

**ENCLOSURE:** - (Type Test shall be done including CT, PT with busbar & enclosure)

Test Details	Type Test To be Conducted on Complete Assembled Enclosure	Remarks
Short-time current tests	Conducted on Metering cubicle with 600/5A CTR	Type Test done on Metering Cubicle with 600/5A will be valid for all CTR
Temperature-rise test		
Ingress Protection test		
Lightning impulse		

**8. TYPE TEST CERTIFICATES:**

The Bidder shall furnish the type test certificates of the offered product in bid for the tests as mentioned as per the corresponding standards. All the tests shall be conducted at CPRI/ERDA/ERTO/Any Govt. Owned NABL Accredited LAB or any other International Laboratory as per the relevant standards of IS and IEC. Type tests shall have been conducted in certified Test laboratories during the period not exceeding 5 years or latest CEA Guidelines from the date of opening the bid. In the event of any discrepancy in the test reports, i.e. any test report not acceptable or any/all type tests (including additional type tests, if any) not carried out, same shall be carried out without any cost implication to TPCODL. Bids without all type test report shall stand disqualified.

**9. PRE-DISPATCH INSPECTION:**

Equipment shall be subjected to inspection by a duly authorized representative of the TPCODL. Inspection may be made at any stage of manufacture at the option of the purchaser and the equipment if found unsatisfactory as to workmanship or material is liable to rejection. Supplier shall grant free access to the places of manufacture to TPCODL's representatives at all times when the work is in progress. Inspection by the TPCODL or it's authorized representatives shall not relieve the supplier of his obligation of furnishing equipment in accordance with the specifications. Material shall be dispatched after specific MDCC (Material Dispatch Clearance Certificate) is issued by TPCODL. Following documents shall be sent along with material.

- A. Test reports
- B. MDCC issued by TPCODL
- C. Invoice in duplicate

- D. Packing list
- E. Drawings & catalogue
- F. Guarantee / Warrantee card
- G. Other Documents applicable)

### **STAGE INSPECTION:**

The manufacturer should have the facility to show the stage inspection i.e during the period of FAT. 01 no of sample from any cubicle will be completely destroyed in the bidder's laboratory in order to check the quality of resin cast, measurement of core Heaterweight, quality of copper used for winding and HV test will be applied for minimum 5 minutes to check the insulation level and the cost for the testing will be borne by the manufacturer.

### **10. INSPECTION AFTER RECEIPT AT STORE:**

The material received at TPCODL Store will be inspected for acceptance and shall be liable for rejection if found different from the reports of the pre-dispatch inspection and one copy of the report shall be sent to Project Engineering department.

### **11. GUARANTEE PERIOD:**

The supplier shall give Guarantee for the satisfactory functioning of the material / equipment as per specification, for a minimum period of **60 months from date of commissioning or 66 months from the last date of receipt of material in good condition at departmental store for each consignment whichever is earlier**. The bidder shall be liable to undertake the replacement or rectify defects at his own cost within mutually agreed timeframe. The bidder shall further be responsible for free replacement for another period of three years from the end of guarantee period for any "latent defect" if noticed and reported to purchaser.

### **12. PACKING:**

Bidder shall ensure that all equipment covered by this specification shall be prepared for rail/road transport (local equipment) and be packed in such a manner as to protect it from damage in transit.

### **13. TENDER SAMPLE:**

One numbers sample should be ready at the firms' works after issue of LOA for new entrant. The sample shall be checked for its suitability and conformity with this specification. The drawing of sample must be attached with bid documents showing all views of equipment installed inside the metering panel along with the sketch of sealing arrangement as mentioned above. After placing of purchase order the material shall be supplied as per the approved sample and specification. However approval of the sample shall not absolve the supplier of his responsibility to supply the material as per specifications.

### **14. TRAINING:**

Not Required

### **15. QUALITY CONTROL:**

The bidder shall submit with the offer, assurance plan indicating the various stages of inspection, the tests and checks which will be carried out on the material of construction, components during manufacture and after finishing, bought out items and fully assembled component and

equipment including drives. As part of the plan, a schedule for stage and final inspection within the parameters of the delivery schedule shall be furnished. The Purchaser's or its nominated representative engineer shall have free access to the manufacturer/sub-supplier's works to carry out inspections.

**16. MINIMUM TESTING FACILITY:**

The manufacturer should have all the testing facilities at their works to carry out all the routine & acceptance test including partial discharge test as mentioned below. List of plant & machinery and test equipment available at manufacturer's works should necessarily be submitted along with tender.

**17. MANUFACTURING ACTIVITIES:**

CAT-B/CAT-A approval is mandatory to start manufacturing works.

**18. SPARES, ACCESSORIES & TOOLS:**

Following spares along with Sl. no. shall be supplied along with Metering Cubicle. The quantity of spare shall be as per below mentioned list:

- a. Current Transformers – 3 nos. for every 5 nos. Metering Cubicle
- b. Potential Transformers - 3 nos. for every 5 nos. Metering Cubicle
- c. HT Fuse - 3 nos. for every 5 nos. Metering Cubicle

**19. DRAWING & DOCUMENTS:**

Following drawings and documents shall be prepared based on

TPCODL specifications and statutory requirements and shall be submitted with the bid:

- a) Completely filled in Technical Particulars
- b) Signed & Stamp of the Specification
- c) All Type Test Reports as per specifications
- d) Clause-wise compliance of the specification
- e) General description of the equipment and all components including brochures.
- f) General arrangement for Metering cubicle
- g) Foundation plan
- h) Bill of material
- i) Experience List and Performance Certificate

Bidder shall be submitted after issuance of order:

- a) Completely filled in Technical Particulars
- b) Signed & Stamp of the Specification
- c) Clause-wise compliance of the specifications
- d) Compliances during technical evaluations
- e) General arrangement for Metering cubicle
- f) Power flow diagram
- g) Foundation plan
- h) Bill of material

All the documents & drawings shall be in English language.

**20. GENERAL TECHNICAL PARTICULAR:**

Clause-wise compliance of the complete specification.

**21. SCHEDULE OF DEVIATIONS:****(TO BE ENCLOSED WITH TECHNICAL BID)**

All deviations from this specification shall be set out by the Bidders, clause by Clause in this schedule. **Unless** specifically mentioned in this Schedule, the tender shall be deemed to confirm the purchaser's specifications:

Sl. No.	Clause No.	Details of deviation with justifications

We confirm that there are no deviations apart from those detailed above

Seal of the Company:

Signature

Designation

**Indicative GA Drawing of 33kV Metering Cubicle**

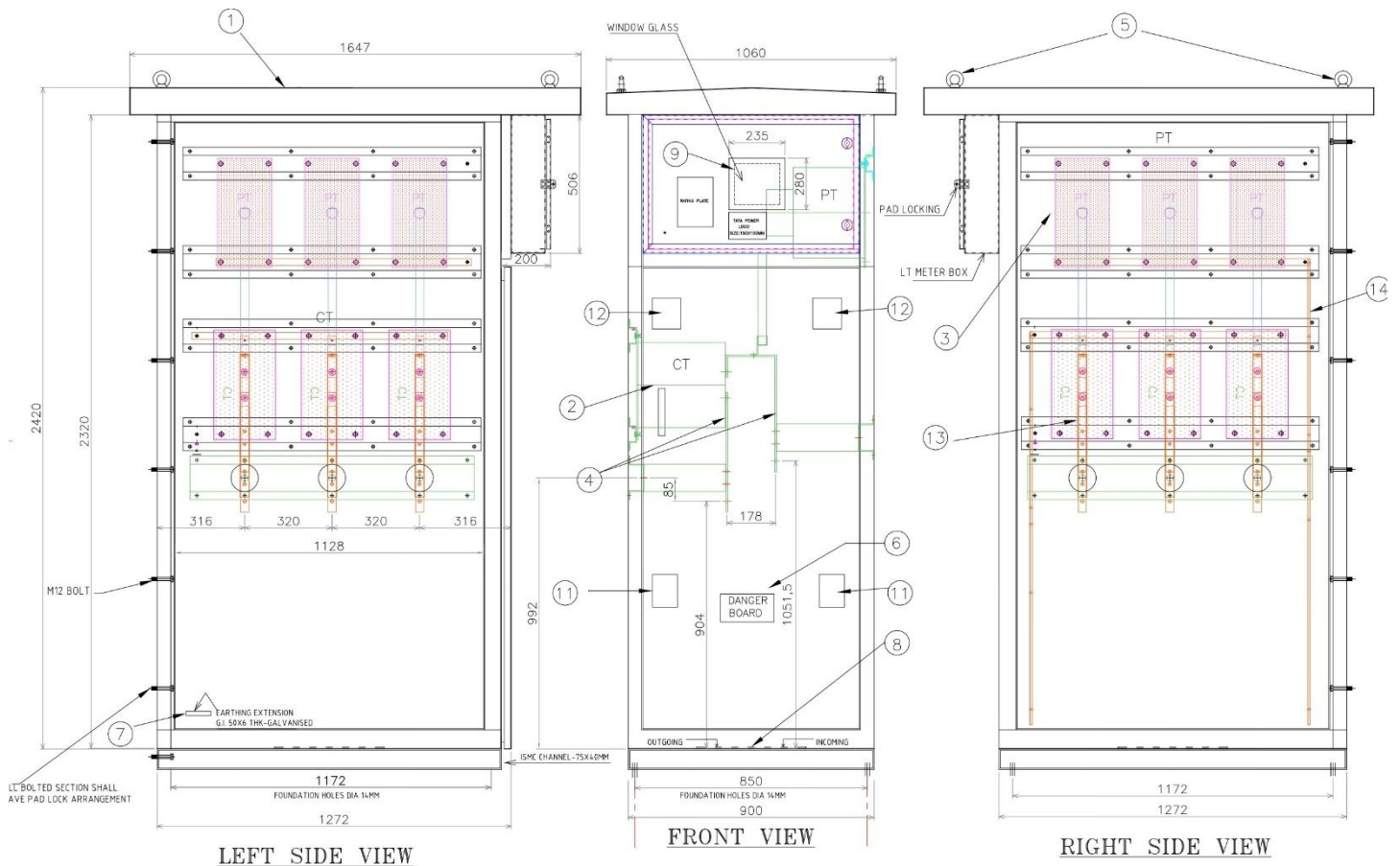

**Note:-**

- If Bidder have Type Tested Design complying all technical parameters of this specification other than above GA drawing that will be accepted
- Bidder should submit all type test reports as per this specification

<b>METERING CUBICLE:</b>		
<b>Sr. No.</b>	<b>Particulars</b>	<b>Parameters</b>
1	Normal system voltage (kV r.m.s)	33
2	Highest system voltage (kV r.m.s)	36
3	Frequency	50HZ
4	Number of Phases	3
5	Impulse withstand voltage (KVpeak) (on assembled CT-PT set)	170 KVpeak
6	Power frequency dry withstand test on	
	(a) primary winding	70kV (rms)
	(b) secondary winding	3kV (rms)
7	Maximum temperature rise over maximum ambient temperature of 45 <sup>0</sup> C at rated continuous thermal current at rated frequency and with rated burden.	110 <sup>0</sup> C (As per IS 16227-1 for Class F Insulation)
8	Cable connection terminal of CT to base plate distance	950mm Minimum
9	Paint (Powder Coating)	RAL 7032
10	Powder Coating Thickness	80 microns
11	Rating/Size of Bus Bar	Tinned Electrolytic Copper Bus Bar size suitable for all rating of metering cubicle shall be 600A
11.a	Maximum Current Density of Copper Bus Bar	1.75 A/sqmm
12	Enclosure	
a.	Material and thickness of the meter box	3mm GI Sheet with Powder Coating, min. thickness of powder coating shall be 80micron. The paint should sustain for harsh environment & saline weather, Corrosion Protection for Panel entire life cycle (minimum 10 yrs).
b.	Non-current carrying nuts, bolts, screws etc. on enclosure	SS 304
c.	Protection against penetration of dust and water	IP 55
d.	Door of metering compartment	Wire Mess & Door of metering compartment
e.	Size of Enclosure (max. allowed)	2400mm (Height) X 1400mm (Length) X 1600mm (Depth) and suitable to inhouse upto CTR 600/5A
f.	Outdoor Application, if required	Suitable Canopy will be provided in outdoor application, so that meters can be viewed properly
g.	System Earthing	Suitable for 25kA/1sec
h.	Size of Earth Bus Bar	25x3mm Copper (This copper bus to be connected to both side M16 Earth Bolt)
i.	Washers and connectors	Bi-metallic washer and tinned copper connector
j.	Cable cleat	HDPE/Nylon Fire retardant cable cleat
k.	Incoming & Outgoing Cable Cleating Arrangement	Suitable for 3Cx400 sqmm and 1Cx630 sqmm
		(Actual size of cable to be provided during drawing approval stage)

<b>CURRENT TRANSFORMERS:</b>		
<b>Sr. No.</b>	<b>Particulars</b>	<b>Parameters</b>
1	Normal system voltage (kV r.m.s)	33
2	Highest system voltage (kV r.m.s)	36
3	Frequency	50HZ
4	Type	Single Phase Indoor Resin Cast
5	Number of CT	3Nos
6	Rated output (VA burden)	10VA.
7	Rated continuous thermal current	1.2 times of rated primary current
8	Short time current rating for 1 sec.	<ul style="list-style-type: none"> <li>• 30/5A CT Ratio to 75/5A CT Ratio – 13.1kA/1sec</li> <li>• 100/5 CT Ratio upto 600/5A - 25kA/1sec</li> </ul>
9	Rated dynamic current (Peak)	2.5 times of short time thermal current rating
10	Instrument security factor	≤ 5
11	Impulse withstand voltage (KVpeak) (on assembled CT-PT set)	170 KVpeak
12	Maximum temperature rise over maximum ambient temperature of 45 <sup>0</sup> C at rated continuous thermal current at rated frequency and with rated burden.	110 <sup>0</sup> C (As per IS 16227-1 for Class F Insulation)
13	Type of Insulation	
13.1	Impregnation	Class H vacuum pressure impregnation
13.b	Varnish on CT-PT windings	Class H varnish
13.c	Epoxy resin casting	Class F Resin
14	Limits of current (ratio) Error and phase Displacement. (For 0.2S Accuracy class)	Within limited of IS:16227 with latest amendment/revision
15	Max. ratio error	Within limited of IS:16227 with latest amendment/revision
16	Max. phase angle error	Within limited of IS:16227 with latest amendment/revision
17	System condition	Effectively earthed system
18	Thickness of base plate	5mm, Plate shall be properly with earthing arrangement
19	Type	Dry type epoxy resin cast
20	Creepage distance	900mm (It is only applicable for Insulator connecting for CT, PT & Cable Compartment, if used)
21	Transformation ratio/ CT ratio	As per above schedule of requirement.
22	No. of cores	1 Nos
23	Rated continuous thermal current temperature rise over ambient	As per IS 16227 latest amendment/revision
24	One minute power frequency voltage withstand test on secondary winding	3kV
25	Class of accuracy	0.2S
26	Secondary termination	S1 & S2 shall be clearly marked
27	CT primary current	Shall be as per tender (30A, 50A, 75A, 100A, 150A, 200A, 300A, 400A, 600A)
28	CT secondary current	5A
29	Total weight of the core before casting of Resin	To be provided by Bidder

30	Total weight of the unit after casting of Resin	To be provided by Bidder
31	Power frequency dry withstand test on (a) primary winding (b) secondary winding	70kV (rms) 3kV (rms)
32	Washers and connectors	Bi-metallic washer and tinned copper connector
33	CT terminal shape	L-shaped or cross flat type
34	Rating/Size of Bus Bar	Tinned Electrolytic Copper Bus Bar size suitable for all rating of metering cubicle shall be 600A

<b>POTENTIAL TRANSFORMERS:</b>		
<b>Sr. No.</b>	<b>Particulars</b>	<b>Parameters</b>
1	Normal system voltage (kV r.m.s)	33
2	Highest system voltage (kV r.m.s)	36
3	Frequency	50HZ
4	Type	Single Phase Indoor Resin Cast
5	Number of phases	Single phase
6	No of PT	3 Nos
7	Rated Output (VA) Burden	30VA
8	Transformation ratio (PT ratio)	33KV/ $\sqrt{3}$ / 110V/ $\sqrt{3}$
9	Impulse withstand voltage (KV peak) (on assembled CT PT set)	170
10	One minute power frequency dry withstand voltage (on assembled CT-PT set)	
	(a) Primary (KV rms)	
	(b) Secondary (KV rms)	70kV 3kV
11	Class of accuracy	0.2
12	Rated voltage factor and time	1.2 times continuous and 1.5 times for 30 sec
17	System condition	Effectively earthed system
18	Maximum temperature raise over maximum ambient temperature (which may be taken as 45°C) at rated frequency and with rated Burden	Within limited of IS: 16227 with latest amendment/ revision.
19	Maximum ratio error	Within limited of IS: 16227 with latest amendment/ revision.
20	Maximum phase angle error	Within limited of IS: 16227 with latest amendment/ revision.
21	Type of Insulation	
21.a	Impregnation	Class H vacuum pressure impregnation
21.b	Varnish on CT-PT windings	Class H varnish
21.c	Epoxy resin casting	Class F Resin
22	Creepage distance	900mm
		(It is only applicable for Insulator connecting for CT, PT & Cable Compartment, if used)
21	Basic insulation Level	36/70/170 KV
22	Thickness of baseplate	5mm, Plate shall be properly with earthing arrangement.
23	Material of Bushings	Epoxy
24	Material for Rod of Bushings	Copper (if Applicable)

**CONTENTS**

1. SCOPE
2. APPLICABLE STANDARDS
3. CLIMATIC CONDITIONS OF INSTALLATION
4. GENERAL TECHNICAL REQUIREMENTS
5. GENERAL CONSTRUCTION
6. NAME PLATE AND MARKING
7. TESTS
8. TYPE TEST CERTIFICATES
9. PRE-DISPATCH INSPECTION
10. INSPECTION AFTER RECEIPT AT STORES
11. GUARANTEE
12. PACKING
13. TENDER SAMPLE
14. TRAINING
15. QUALITY CONTROL
16. MINIMUM TESTING FACILITIES
17. MANUFACTURING ACTIVITIES
18. SPARES, ACCESSORIES AND TOOLS
19. DRAWINGS AND DOCUMENTS
20. GUARANTEED TECHNICAL PARTICULARS
21. SCHEDULE OF DEVIATIONS

**1. SCOPE:**

The specification covers the design, manufacture, testing and supply of 11kV Indoor as well as Outdoor Type Metering cubicle & resin cast CT & PT for metering cubicle made of GI Sheet with Powder Coating.

- The metering Cubicle shall be totally enclosed, air insulated dust and vermin proof having two separate compartments HT (lower) & LT (upper) provided with two separate doors, hinged inside the box. The 11kV metering cubicle shall comply with the requirements of Indian Electricity Rule 1956 & as per relevant IS.
- The metering cubicle shall be supplied with 3nos. of 11kV single phase epoxy resin cast CT's & 3nos. of 11kV epoxy resin cast PT's and suitable clamping arrangement for holding 11kV incoming and outgoing cables and holding CTs & PTs.
- All the equipment shall comply with the requirement of relevant IS specification.

**2. APPLICABLE STANDARDS:**

Except where modified by this specification the component parts of the equipment shall comply with the following IS available (the latest versions).

- Specification for Instrument Transformers : IS 16227 (Part-1 to 4)
- HV Porcelain Bushing :IS 2099
- Galvanization: IS 2633
- Primary Terminals : IS 10601
- Hollow Pressurized and Unpressurized Ceramic and Glass Insulators for Use in Electrical Equipment with Rated Voltages Greater Than 1 000 V : IS/IEC 62155
- Insulated Bushings for Alternating Voltages above 1 000 V : IS/IEC 60137
- Electrical Insulation-thermal Evaluation and Designation : IS 1271 ( IEC 60085)
- Electric Power Connectors- Specification : IS 5561
- General requirements - Enamelled round copper wire : IEC 60137-0-1
- Degrees of protection provided by enclosures (IP code) : IEC 60529
- Specification for instrument Transformer : IEC 61869

**3. CLIMATIC CONDITIONS OF THE INSTALLATION:**

1	Maximum ambient temperature	55 deg C
2	Max. Daily average ambient temp	45 deg C
3	Min Ambient Temperature	0 deg C
4	Maximum Humidity	95%
5	Average Annual Rainfall	150cm
6	Average No. of rainy days per annum	120
7	Altitude above MSL not exceeding	1000m
8	Wind Pressure	300 Km/hr
9	Earthquakes of an intensity in horizontal direction	Equivalent acceleration of 0.3g
10	Earthquakes of an intensity in vertical direction	Equivalent to seismic acceleration of 0.15g (g being acceleration due to gravity)

TPCODL service area has **heavy saline conditions along the coast and High cyclonic Intensity winds with speed up to 300 Km ph.** The atmosphere is generally laden with mild acid and dust in suspension during the dry months and is subjected to fog in cold months.

#### 4. GENERAL TECHNICAL REQUIREMENT:

##### METERING CUBICLE:

Sr. No.	Particulars	Parameters
1	Normal system voltage (kV r.m.s)	11
2	Highest system voltage (kV r.m.s)	12
3	Frequency	50HZ
4	Number of Phases	3
5	Impulse withstand voltage (KVpeak) (on assembled CT-PT set)	75 KVpeak
6	Power frequency dry withstand test on (a) primary winding (b) secondary winding	28kV (rms) 3kV (rms)
7	Maximum temperature rise over maximum ambient temperature of 45°C at rated continuous thermal current at rated frequency and with rated burden.	110°C (As per IS 16227-1 for Class F Insulation)
8	Cable connection terminal of CT to base plate distance	750mm Minimum
9	Paint (Powder Coating)	RAL 7032
10	Powder Coating Thickness	80 microns
11	Rating/Size of Bus Bar	Tinned Electrolytic Copper Bus Bar size suitable for all rating of metering cubicle shall be 400A
11.a	Maximum Current Density of Copper Bus Bar	1.75 A/sqmm
12	Enclosure	
a.	Material and thickness of the meter box	3mm GI Sheet with Powder Coating, min. thickness of powder coating shall be 80micron. The paint should sustain for harsh environment & saline weather, Corrosion Protection for Panel entire life cycle (minimum 10 yrs).
b.	Non-current carrying nuts, bolts, screws etc. on enclosure	SS 304
c.	Protection against penetration of dust and water	IP 55
d.	Door of metering compartment	Wire Mess & Door of metering compartment

e.	Size of Enclosure (max. allowed)	1700mm (Height) X 1000mm (Length) X 1200mm (Depth) and suitable to inhouse upto CTR 400/5A
f.	Outdoor Application, if required	Suitable Canopy will be provided in outdoor application, so that meters can be viewed properly
g.	System Earthing	Suitable for 25kA/1sec
h.	Size of Earth Bus Bar	25x3mm Copper (This copper bus to be connected to both side M16 Earth Bolt)
i.	Washers and connectors	Bi-metallic washer and tinned copper connector
j.	Cable cleat	HDPE/Nylon Fire retardant cable cleat
k.	Incoming & Outgoing Cable Cleating Arrangement	Suitable for 3Cx400 sqmm & 1Cx400 sqmm (Actual size of cable to be provided during drawing approval stage)

#### CURRENT TRANSFORMERS:

There shall be three number single core single ratio dry type epoxy resin cast, current transformers conforming to IS/IEC latest amendments thereof as per details mentioned below:-

Sr. No.	Particulars	Parameters
1	Normal system voltage (kV r.m.s)	11
2	Highest system voltage (kV r.m.s)	12
3	Frequency	50HZ
4	Type	Single Phase Indoor Resin Cast
5	Number of CT	3Nos
6	Rated output (VA burden)	10VA.
7	Rated continuous thermal current	1.2 times of rated primary current
8	Short time current rating for 1 sec.	<ul style="list-style-type: none"> <li>30/5A CT Ratio to 75/5A CT Ratio – 13.1kA/1sec</li> <li>100/5 CT Ratio upto 400/5A - 25kA/1sec</li> </ul>
9	Rated dynamic current (Peak)	2.5 times of short time thermal current rating
10	Instrument security factor	≤ 5
11	Impulse withstand voltage (KVpeak) (on assembled CT-PT set)	75 KVpeak
12	Maximum temperature rise over maximum ambient temperature of 45°C at rated continuous thermal current at rated frequency and with rated burden.	110°C (As per IS 16227-1 for Class F Insulation)

13	Type of Insulation	
13.a	Impregnation	Class H vacuum pressure impregnation
13.b	Varnish on CT-PT windings	Class H varnish
13.c	Epoxy resin casting	Class F Resin
14	Limits of current (ratio) Error and phase Displacement. (For 0.2S Accuracy class)	Within limited of IS:16227 with latest amendment/revision
15	Max. ratio error	Within limited of IS:16227 with latest amendment/revision
16	Max. phase angle error	Within limited of IS:16227 with latest amendment/revision
17	System condition	Effectively earthed system
18	Thickness of base plate	5mm, Plate shall be properly with earthing arrangement
19	Type	Dry type epoxy resin cast
20	Creepage distance	300mm (It is only applicable for Insulator connecting for CT, PT & Cable Compartment, if used)
21	Transformation ratio/ CT ratio	As per above schedule of requirement.
22	No. of cores	1 Nos
23	Rated continuous thermal current temperature rise over ambient	As per IS 16227 latest amendment/revision
24	One minute power frequency voltage withstand test on secondary winding	3kV
25	Class of accuracy	0.2S
26	Secondary termination	S1 & S2 shall be clearly marked
27	CT primary current	Shall be as per tender (30A, 50A, 75A, 100A, 150A, 200A, 300A, 400A)
28	CT secondary current	5A
29	Total weight of the core before casting of Resin	To be provided by Bidder
30	Total weight of the unit after casting of Resin	To be provided by Bidder
31	Power frequency dry withstand test on (c) primary winding (d) secondary winding	28kV (rms) 3kV (rms)
32	Washers and connectors	Bi-metallic washer and tinned copper connector
33	CT terminal shape	L-shaped or cross flat type
34	Rating/Size of Bus Bar	Tinned Electrolytic Copper Bus Bar size suitable for all rating of metering cubicle shall be 400A

**N.B.** - The dimension of the CT base plate should be **285mm** length from hole to hole and **140mm** width from hole to hole. The base plate should have open slot arrangement for adjustable fixing. Plate should be properly with earthing arrangement.

#### POTENTIAL TRANSFORMERS:

Details specification as per IS/IEC with latest amendments.

Sr. No.	Particulars	Parameters
1	Normal system voltage (kV r.m.s)	11
2	Highest system voltage (kV r.m.s)	12
3	Frequency	50HZ
4	Type	Single Phase Indoor Resin Cast
5	Number of phases	Single phase
6	No of PT	3 Nos
7	Rated Output (VA) Burden	30VA
8	Transformation ratio (PT ratio)	11KV/ $\sqrt{3}$ / 110V/ $\sqrt{3}$
9	Impulse withstand voltage (KV peak) (on assembled CT PT set)	75
10	One minute power frequency dry withstand voltage (on assembled CT-PT set) (a) Primary (KV rms) (b) Secondary (KV rms)	28kV 3kV
11	Class of accuracy	0.2
12	Rated voltage factor and time	1.2 times continuous and 1.5 times for 30 sec
17	System condition	Effectively earthed system
18	Maximum temperature raise over maximum ambient temperature (which may be taken as 45°C) at rated frequency and with rated Burden	Within limited of IS 16227 with latest amendment/ revision.
19	Maximum ratio error	Within limited of IS 16227 with latest amendment/ revision.
20	Maximum phase angle error	Within limited of IS 16227 with latest amendment/ revision.
21	Type of Insulation	
21.a	Impregnation	Class H vacuum pressure impregnation
21.b	Varnish on CT-PT windings	Class H varnish
21.c	Epoxy resin casting	Class F Resin
22	Creepage distance	300mm (It is only applicable for Insulator connecting for CT, PT & Cable Compartment, if used)
21	Basic insulation Level	12/28/75 KV

22	Thickness of baseplate	5mm, Plate shall be properly with earthing arrangement.
23	Material of Bushings	Epoxy
24	Material for Rod of Bushings	Copper (if applicable)

**N.B.-** The dimension of the PT base plate should be **270mm** length from hole to hole and **125mm** width from hole to hole (the hole is slotted). The base plate should have open slot arrangement for adjustable fixing, with proper earthing arrangement diagonally.

#### 5. GENERAL CONSTRUCTION:

The 11KV metering cubicle panel shall be fabricated with 3mm GI sheet. The overall dimensions of the cubicle shall be 1700mm (Height) X 1000mm (Length) X 1200mm (Depth) and it shall be suitable for 400A CT Ratio and Busbar. Total height including base channel will be 1800mm. Height of panel is fixed. Dimension of width & depth may be increased suitably to accommodate CTs/PTs, if required. These dimensions may vary slightly as per design of manufacturer taking into care the minimum clearance of 230mm between phases as well as between phase and earth. Space for installation of energy meter should be modified to accommodate smart meter dimension (H-300 x W-200 x D-100).

- All the edges and joints shall be made and welded in such a way that no access inside the cubicle shall be possible and shall thus provide strength to robust mechanical structure both during transportation and installation.
- The metering cubicle shall be welded with 4 numbers lifting lugs of adequate strength at suitable diagonal locations for balanced lifting. All the edges and joints shall be made and welded in such a way so that no access inside the cubicle shall be possible through them and shall thus provide strength to robust mechanical construction both for transportation and installation for its use.
- The metering cubicle shall be totally enclosed and shall be provided with two nos. hinged door made of GI sheet which shall rest on the collar along the four sides of cubicle so that the door remain flushed with body of the cubicle.
- The hinge of the doors shall be concealed type (proper welded from inside) so as to eliminate any chance of de-hinging without causing any damage to the cubicle.
- The Metering cubicle shall be provided with MS channels support of 100mm x 50mm 5mm welded at bottom along it's length 1400mm.
- The metering cubicle shall be provided with M16 earthing bolt at two opposite sites with welding from inside the cubicle for fixing external earth during installation. Both earthing bolts at opposite ends to be interconnected by 25x3mm Copper. The bolts shall be connected internally to 25x3 mm Copper earth bus which shall provide earthing to PT neutral & cable earth provision. Terminal bolts and washers used in metering cubicle shall be of stainless steel.
- Each of the supporting channel shall have two holes of 12mm of dia. suitable for foundation bolts.
- The Metering cubicle shall be provided with MS Earthing strip of size 50mm x 5mm welded at the two opposite base angles provided with welded nut of 6mm dia. welded from inside

the cubicle. The earthing strip can be connected by tightening a bolt from outside the metering cubicle at two opposite ends.

- The panel should be provided with 4nos. of lifting hooks.
- The metering cubicle shall have two separate compartments separated by GI sheet of 2.0mm thickness as given below.
- 2 nos. 60 W space heater to be provided with individual thermostat for each heater
- The heater must be kept on both corner side of the cubicle chamber with operating switch must kept outside. Thermostat shall be connected through separate MCB.
- 2 nos. Dehumidifier shall be given along with each heater circuit to arrest the humidity. (Make of dehumidifier shall be approved during drawing approval)

230VAC SUPPLY (CUSTOMER SCOPE)

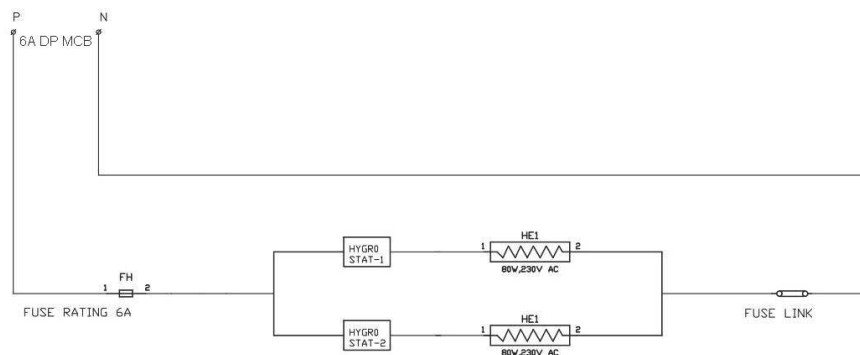

- Wire Mess to be provided on the viewing window before the toughened Glass.
- Corrosion resistant paint to be provided to avoid rusting as we are operating in saline belt.
- Secondary wiring shall be carried out with 1100V grade PVC insulated stranded copper conductor of 4.0 sq mm for CT circuit and 2.5 Sq.mm for PT and the other circuits.
- Normal current density shall not be more than 1.6 A sq mm in primary winding of the CT
- Busbar shall be made of electrical Grade copper and of suitable size to withstand the specified short circuit rating.
- HT terminals to the base plate distance shall be minimum 750mm.
- Support insulators to be provided for bus bars wherever required to provide sufficient strength
- The mounting arrangement of the CT shall be such that in-case of replacement of existing CT with higher or lower size will not require any alterations.
- 1no. 15A Switch & socket, 9W LED light with fittings shall be provided in the LT compartment

**UPPER (LT) COMPARTMENT:**

- The upper compartment of the metering cubicle shall be called LT compartment and shall have approximate height of 550mm. The compartment shall have provision for housing a tri-vector meter along with its associated wiring. The upper compartment will be one sided hinged double door type and the arrangement for meter fixing will be in inner portion.
- For fixing of KWH tri-vector meter in this compartment, four nos. MS slotted angles of suitable size shall be welded to the body from inside of partition chamber in LT compartment, two nos. slotted angles shall be bolted vertically and two nos. horizontally, which shall be movable forming to adjust the distance and height of meter to be fixed in the compartment.
- The upper compartment shall be provided with one door fabricated in one piece and hinged as per clause no. - 2.3. The door shall be provided with synthetic/semi synthetic gasket to make it dust & vermin proof. The door shall be provided with a handle and two nos. sealing arrangement. There shall be fixed (non-openable) window (approximate size 300mm x 200mm) fitted with transparent acrylic glass. The glass shall be fitted/ tightened with MS frame from inside of window. The height of the window shall be such that the reading can be taken easily from outside).
- The secondary wiring should be 4sqmm multi-strand coloured wires with Ferrules & all PT & CT secondary wires to be R Y B N colour coded.
- All wires will be colour coded (Red, Yellow, Blue, Black, Gray). The Secondary connection to be kept on front side for easy accessibility and ensure tightness.
- Earthing provision to be provided for CT Secondary Wire (S2).
- Two types of PT primary Grounding should be provided one is through strip & other through cable
- Additional non-resettable counter to be provided on door and kept on record for number of operations it is used.

**The LT compartment shall essentially contain the following:**

- Hanger of slotted angle for mounting main meter (Schneider, SECURE, HPL, GENUS make etc.) for having flexibility for mounting of meter vertically and horizontally (meter not in scope of this tender supply).

**LOWER (HT) COMPARTMENT:**

- The lower compartment of metering cubicle shall be called HT compartment and shall have approximate height of 1250mm.
- This compartment shall be housed three nos. 11kV single phase epoxy resin cast CT's for 'R', 'Y' and 'B' phase and three nos. 11kV single-phase epoxy resin cast PT's, connecting strip between CT's and PT's, bus bar with suitable clamping arrangement for incoming and outgoing 11kV XLPE cables. There shall be two nos. sealing arrangement diagonally in base of each CT & PT.

- The door of lower compartment shall be provided with one door fabricated in one pieces and hinged as per clause no. - 2.3 such that it becomes complete dust and vermin proof. The door shall be provided with a handle and two nos. sealing arrangement.
- The compartment should be provided with two nos. cable entries with detachable plate with brass glands of appropriate size at the bottom suitable for 11kV XLPE cable for appropriate current rating.

**The HT compartment shall be essentially contain the following:**

- 11kV epoxy resin cast CT's (single phase) - 03nos.
- 11kV/ $\sqrt{3}$ /110V/ $\sqrt{3}$  epoxy resin cast PT's (single phase) - 03nos.
- Flexible copper flat strip of 30 x 0.4mm or 8 SWG copper wire (duly insulated) to connect PT's to bus bar of CT's - 01set
- LT wiring for the secondary of CT & PT circuit, which should not less than 4 mm<sup>2</sup> copper in size - 01set
- 11kV PT primary must have 2A HT Fuse (HRC Type, Make - Bushman, Eswori, Pheonix, L&T) whereas secondary side directly connected to 3Ph 4wire Screw type front connection standard TTB (TPCODL Approved make –DAV / IMP/ Welstar) instead of coming through MCCB. Coloured Lead wires without lugs (12inches) to be provided for connection from TTB to meter.

**SEALING:**

The metering cubicles shall be completely lockable and sealable with at least one locking and two sealing arrangements of the door of each compartment. Apart from sealing arrangement of both compartments, mounting bolts of CTs and PT shall have the provisions for sealing arrangement so that removal of CTs & PTs from the installed positions in the panel (for tampering/ replacement) by the unauthorized person is not possible without breaking/ tampering the sealing arrangement. The hinge arrangement, sealing of CTs and sealing of PTs shall be diagonally arranged in the base of each CTs & PTs.

Sealing arrangement for all Doors (Front, Back and Top) of the CTPT. Sealing arrangement to be provided for meter chamber & CT/PT Chamber. Sealing arrangement to be provided on the secondary terminals (Casing type).

This sealing arrangement shall be checked by the officers at the time of checking of sample and during inspection. CT/PT secondary terminal should have a provision for sealing.

The epoxy resin casting of 11 kV CTs & PTs coils is required to be carried out under vacuum to avoid any blow holes in the casted material. To establish this Epoxy hardener and accelerator, if any is mixed in the mixing chamber under the vacuum and poured into the dyes placed in the casting chamber which is also kept under vacuum as per relevant IS specifications. The temperature as specified by the Epoxy manufacturer is maintained with thermostatic control so that all the moisture is also drained out under vacuum.

**METERING COMPARTMENT:**

- The CT secondary s1 terminal & PT secondary phase terminal of each phase shall terminate at TTB from bottom side.
- The CT secondary s2 & PT secondary neutral wires shall be wired to droppable terminal links & then to TTB.
- Make of droppable links shall be Connectwell or Elmex
- CT & PT Star formation to be made at terminal links.
- The TTB, wiring shall be carried out with source wires from CT and PT at bottom and meters wires at top. Only front connection screw type standard TTBs should be used and shall be located inside the metering panel and not on the panel door.
- TTB shall be of DAV make & Model name is SSFS.
- No lugs shall be provided for wires to meter & TTB.
- Adequate space for mounting TVM should be provided in compartment (Max dimension envisaged for Meter. Location of meter shall be at convenient height (less than five feet from ground level) for easy reading & testing purpose. Window to be provided for taking meter reading manually from outside without opening of cubicle.
- Please refer below diagram for meter wiring

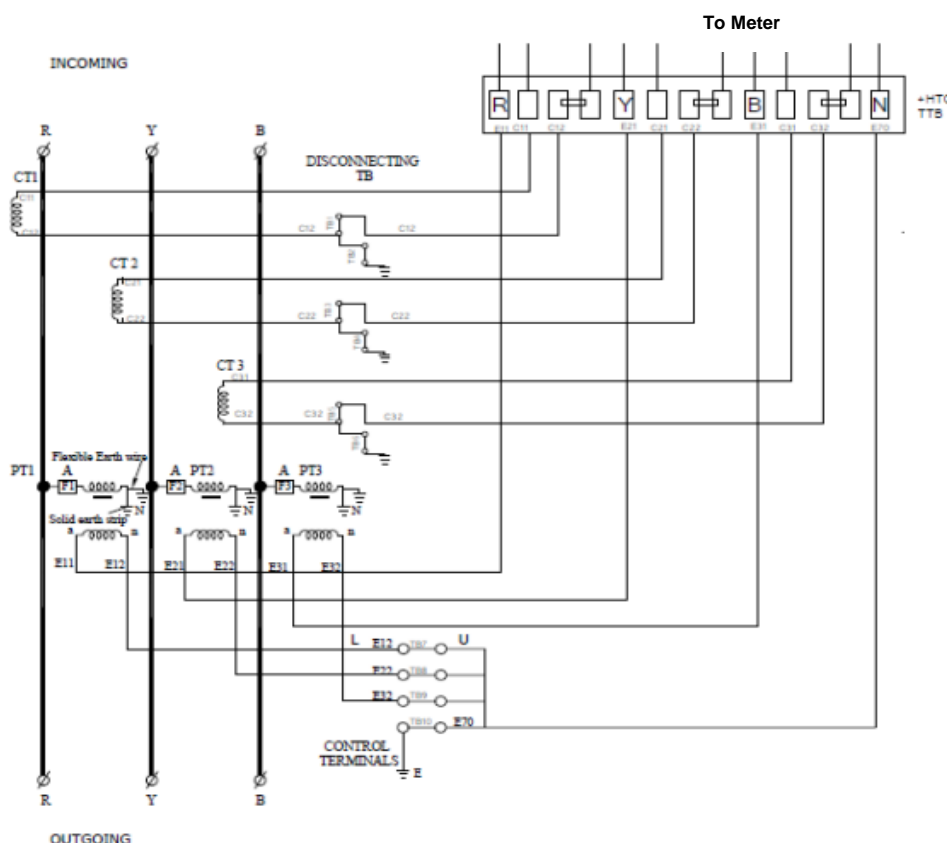

**CABLE COMPARTMENT:**

- The cable compartment shall be provided with warning on door “DANGER 11kV DO NOT OPEN THIS DOOR BEFORE SWITCH OFF THE SUPPLY”.
- Suitable provision shall be made inside the compartment with proper clamping arrangement. Provision of suitable space and arrangement of proper orientation of cable termination shall be made so that there is no problem in fixing the incoming and outgoing cables. The cable size shall be 11KV, 3 Core XLPE 400 sq.mm. Suitable non-magnetic cable support shall be provided on both sides for the HT cables. The CT mounting shall be made in such a way to avoid easy access or removal.
- The Incoming and outgoing marking to be done with paint on metering cubicle.

**BUSHING:**

- The metering equipment shall be supplied with adequate number of single terminals, epoxy bushings of reputed make (as approved by the Purchaser) with Brass studs as per the rating.
- The bushings shall be rated for 12 kV. The bushings shall confirm to IS: 8603 for the dimensions and IS: 5621 and IS: 2099 for other electrical requirements.

**PAINTING:**

- All paint shall be applied on clean dry surfaces under suitable atmospheric conditions by seven tank process and powder coating.
- The overall paint thickness (External & Internal) shall not be less than 80 microns.
- The paint shall not scale off or crinkle or be removed by abrasion during normal handling.
- The enclosure of the CT-PT unit shall be painted with RAL 7032 Siemens grey.

**WINDINGS & CORE:**

- Both primary and secondary winding of CT and PT must be dry type.
- Winding insulation used for PT primary must be of grade 3.
- Winding insulation used for CT primary must be of class H only.
- All windings of CT and PT must undergo vacuum pressure impregnation with varnish of reputed make suitable for withstanding maximum temperature as per Class 'H'.
- After varnish impregnation all coils to be undergo epoxy resin casting with 'F' class of reputed make. Leads shall be brought out from resin casting.
- The core material of CT-PT unit shall be of high grade non ageing electrical silicon steel (CRGO) of first quality having low hysteresis loss and high permeability to ensure accuracy at both terminal and over current voltage. The grade of the Core shall be ZDKH or better.
- The paper used for insulation shall be of high insulation grade. The insulating paper / polyester film used for insulation shall be of high insulation grade, excellent mechanical strength (tensile, tear, and stretch), high purity, chemical stability, and heat resistance. The paper density if the used shall be approx 60-190 g/m<sup>2</sup>. The insulating paper shall be used of make Weidmann or better/ polyester film shall be used of makes herztmann/ Dr. Beck/ Resin or better.
- The insulating materials for winding between HV and LV and between interlayer of the winding and for end turn shall be as per relevant IS. However, end turns have to be provided with reinforced insulation and lead connecting the bushing shall be provided with extra insulation.
- No joints shall be allowed in CT secondary wires.
- The secondary winding shall be epoxying cast and the leads shall be brought out through epoxy cast terminal.

- The wiring shall be neatly bunched together. Only 6 wires of CT and 6 wires of PT shall come out from the chamber for connections.
- Suitable size of lugs shall be used to tighten the wire with the unit's secondary terminals.
- The bus bar and HT side of PT shall be connected through a flexible copper strip or equivalent size of copper and of adequate length such that HT terminals of PTs are not subjected to any compression or tension forces.

## 6. NAME PLATE & MARKING:

An Aluminum foil plate shall be affixed on the front of cubicle to indicate the following information against which the desired information is required to be painted at site: -

- TPCODL/TPSODL/TPNODL/TPWODL property
- Manufacturer's name
- Month and Year of manufacture
- Serial number and Type designation
- Rated primary and secondary currents
- Rated frequency
- Insulation Class (F) of CT & PT
- Rated output and the corresponding accuracy class
- Highest system voltage
- Rated insulation level of primary neutral
- Rated short time thermal current
- Rated dynamic current if different than 2.5 times the rated STC rating
- Rated primary and secondary voltage
- Rated voltage factor and corresponding rated time
- Number of phases and method of connection
- Earthed or unearthed
- Guarantee period
- Reference standard
- Material code
- PO No & Date
- Panel CT ratio & accuracy class(0.2s)
- Panel PT ratio & accuracy class (0.2)
- Meter CT ratio
- Meter PT ratio
- Over all CT-PT multiplying factor
- Sanctioned load
- Date of release of connection

Warranty up to in addition to the above, one no. rating and diagram plate made of Aluminum 1mm thickness shall be provided on the front door of the HT compartment giving details viz. Serial no. of cubicle CT & PT, ratio, burden, class of accuracy, insulation class, year of manufacturing, total weight, P.O. Number and date etc.

Also, the danger plate should be shown on the front cover. Incoming and outgoing to be marked from inside of the panel (on sidewalls), and CT should be marked with P1 and P2 on the resin casting.

Following Marking on CT shall be provided (marking plate on CT shall be made of Aluminum of 1mm thickness):-

- Ratio
- Reference Standard

- Insulation Class (F)
- Burden
- Accuracy Class
- Short Time Withstand Current
- ISF
- Weight
- Serial No.
- MM/YEAR of Manufacturing
- Frequency
- System Voltage
- Basic Insulation Level (BIL)
- Manufacturer Name

Following Marking on PT shall be provided (marking plate on PT shall be made of Aluminum of 1mm thickness):-

- Ratio
- Reference Standard
- Insulation Class (F)
- Burden
- Accuracy Class
- Weight
- Serial No.
- MM/YEAR of Manufacturing
- Frequency
- System Voltage
- Basic Insulation Level (BIL)
- Manufacturer Name

Further the following shall be painted on the front with black colour and yellow background:

- Serial number
- Year of manufacture
- Ratio

## 7. TEST:

### **CALIBRATION:**

All instruments used in inspection and testing should be properly calibrated and sealed from any Govt. Test House/ Reputed Agency certified by NABL and the reports shall not be less than one year old. Calibration certifications when demanded by inspecting officers shall be provided/ produced for verification purpose.

### **ROUTINE, ACCEPTANCE & TYPE TEST:**

All routine, acceptance & type tests shall be carried out separately in accordance with the relevant IS/IEC. All routine/acceptance tests shall be witnessed by the purchaser/his authorized representative. All the components shall also be type tested as per the relevant standards.

**Stage Inspection:** The manufacturer should have the facility to show the stage inspection i.e. during the period of FAT.

01 no. of Sample from any Cubicle will be completely destroyed in the bidder's laboratory in order to check the quality of resin, measurement of core weight, quality of copper used for winding and HV test will be applied for minimum 5 minutes to check the insulation level and the cost for the testing will be borne by the manufacturer

#### ROUTINE & ACCEPTANCE TESTS:

##### CURRENT TRANSFORMERS:

- Verification of terminal marking and polarity.
- High voltage power frequency test on Primary winding
- High voltage power frequency test on Secondary winding
- Over voltage inter-turn test.
- Determination of errors according to the requirement of accuracy class (0.2s)
- Partial discharge test in accordance with IS: 11322/1985

##### POTENTIAL TRANSFORMER:

- Verification of terminal marking and polarity.
- Power frequency dry withstand test on Primary
- Power frequency withstand test on Secondary
- Determination of errors according to the requirement of accuracy class (0.2)
- Partial discharge test measurement test in accordance with IS: 11322/1985.

#### TYPE TESTS :

The following shall constitute the type tests as per relevant IS:

##### CURRENT TRANSFORMERS:

Test Details	Type Test To be Conducted on Individual CTs	Remarks
Short-time current tests	1. STC Conducted on 30/5A CTR with 13.1kA/1sec 2. STC Conducted on 100/5A CTR with 25kA/1sec	1. STC Type Test done on 30/5A CTR will be applicable upto 75/5A CTR 2. STC Type Test done on 100/5A CTR will be applicable upto 400/5A CTR
Temperature-rise test	1. Type Test Conducted on 75/5A CTR 2. Type Test Conducted on 400/5A CTR	1. Type Test done on 75/5A CTR will be valid for lower CT Ratios (30/5A & 50/5A) 2. Type Test done on 400/5A CTR will be valid for lower CT Ratios (300/5A, 200/5, 150/5 & 100/5A)
Lightning impulse test		
Power frequency withstand test		
Determination of errors according to the requirement of accuracy class.		
Instrument Security Current Test		

**POTENTIAL TRANSFORMERS:**

- Temperature-rise test
- Lightning impulse test
- Power frequency withstand test
- Determination of errors according to the requirement of accuracy class.

**ENCLOSURE:** - (Type Test shall be done including CT, PT with busbar & enclosure)

Test Details	Type Test To be Conducted on Complete Assembled Enclosure	Remarks
Short-time current tests	Conducted on Metering cubicle with 400/5A CTR	Type Test done on Metering Cubicle with 400/5A will be valid for all CTR
Temperature-rise test		
Ingress Protection test		
Lightning impulse		

**8. TYPE TEST CERTIFICATES:**

The Bidder shall furnish the type test certificates of the offered product in bid for the tests as mentioned as per the corresponding standards. All the tests shall be conducted at CPRI/ERDA/ERTO/Any Govt. Owned NABL Accredited LAB or any other International Laboratory as per the relevant standards of IS and IEC. Type tests shall have been conducted in certified Test laboratories during the period not exceeding 5 years or latest CEA Guidelines from the date of opening the bid. In the event of any discrepancy in the test reports, i.e. any test report not acceptable or any/all type tests (including additional type tests, if any) not carried out, same shall be carried out without any cost implication to TPCODL. Bids without all type test report shall stand disqualified.

**9. PRE-DISPATCH INSPECTION:**

Equipment shall be subjected to inspection by a duly authorized representative of the TPCODL. Inspection may be made at any stage of manufacture at the option of the purchaser and the equipment if found unsatisfactory as to workmanship or material is liable to rejection. Supplier shall grant free access to the places of manufacture to TPCODL's representatives at all times when the work is in progress. Inspection by the TPCODL or it's authorized representatives shall not relieve the supplier of his obligation of furnishing equipment in accordance with the specifications. Material shall be dispatched after specific MDCC (Material Dispatch Clearance Certificate) is issued by TPCODL. Following documents shall be sent along with material.

- A. Test reports
- B. MDCC issued by TPCODL
- C. Invoice in duplicate
- D. Packing list
- E. Drawings & catalogue
- F. Guarantee / Warrantee card
- G. Other Documents applicable)

**STAGE INSPECTION:**

The manufacturer should have the facility to show the stage inspection i.e. during the period of FAT. 01 no of sample from any cubicle will be completely destroyed in the bidder's laboratory in order to check the quality of resin cast, measurement of core Heater weight, quality of copper used for winding and HV test will be applied for minimum 5 minutes to check the insulation level and the cost for the testing will be borne by the manufacturer.

**10. INSPECTION AFTER RECEIPT AT STORE:**

The material received at TPCODL Store will be inspected for acceptance and shall be liable for rejection if found different from the reports of the pre-dispatch inspection and one copy of the report shall be sent to Project Engineering department.

**11. GUARANTEE PERIOD:**

The supplier shall give Guarantee for the satisfactory functioning of the material / equipment as per specification, for a minimum period of **60 months from date of commissioning or 66 months from the last date of receipt of material in good condition at departmental store for each consignment whichever is earlier**. The bidder shall be liable to undertake the replacement or rectify defects at his own cost within mutually agreed timeframe. The bidder shall further be responsible for free replacement for another period of three years from the end of guarantee period for any "latent defect" if noticed and reported to purchaser.

**12. PACKING:**

Bidder shall ensure that all equipment covered by this specification shall be prepared for rail/road transport (local equipment) and be packed in such a manner as to protect it from damage in transit.

**13. TENDER SAMPLE:**

One numbers sample should be ready at the firms' works after issue of LOA for new entrant. The sample shall be checked for its suitability and conformity with this specification. The drawing of sample must be attached with bid documents showing all views of equipment installed inside the metering panel along with the sketch of sealing arrangement as mentioned above. After placing of purchase order the material shall be supplied as per the approved sample and specification. However approval of the sample shall not absolve the supplier of his responsibility to supply the material as per specifications.

**14. TRAINING:**

Not Required

**15. QUALITY CONTROL:**

The bidder shall submit with the offer, assurance plan indicating the various stages of inspection, the tests and checks which will be carried out on the material of construction, components during manufacture and after finishing, bought out items and fully assembled component and equipment including drives. As part of the plan, a schedule for stage and final inspection within the parameters of the delivery schedule shall be furnished. The Purchaser's or its nominated representative engineer shall have free access to the manufacturer/sub-supplier's works to carry out inspections.

**16. MINIMUM TESTING FACILITY:**

The manufacturer should have all the testing facilities at their works to carry out all the routine & acceptance test including partial discharge test as mentioned below. List of plant & machinery and test equipment available at manufacturer's works should necessarily be submitted along with tender.

**17. MANUFACTURING ACTIVITIES:**

CAT-B/CAT-A approval is mandatory to start manufacturing works.

**18. SPARES, ACCESSORIES & TOOLS:**

Following spares along with Sl. no. shall be supplied along with Metering Cubicle. The quantity of spare shall be as per below mentioned list:

- a. Current Transformers – 3 nos. for every 5 nos. Metering Cubicle
- b. Potential Transformers - 3 nos. for every 5 nos. Metering Cubicle
- c. HT Fuse - 3 nos. for every 5 nos. Metering Cubicle

**19. DRAWING & DOCUMENTS:**

Following drawings and documents shall be prepared based on

TPCODL specifications and statutory requirements and shall be submitted with the bid:

- a) Completely filled in Technical Particulars
- b) Signed & Stamp of the Specification
- c) All Type Test Reports as per specifications
- d) Clause-wise compliance of the specification
- e) General description of the equipment and all components including brochures.
- f) General arrangement for Metering cubicle
- g) Foundation plan
- h) Bill of material
- i) Experience List and Performance Certificate

Bidder shall be submitted after issuance of order:

- a) Completely filled in Technical Particulars
- b) Signed & Stamp of the Specification
- c) Clause-wise compliance of the specifications
- d) Compliances during technical evaluations
- e) General arrangement for Metering cubicle
- f) Power flow diagram
- g) Foundation plan
- h) Bill of material

All the documents & drawings shall be in English language.

**20. GENERAL TECHNICAL PARTICULAR:**

Clause-wise compliance of the complete specification.

21. SCHEDULE OF DEVIATIONS:

**(TO BE ENCLOSED WITH TECHNICAL BID)**

All deviations from this specification shall be set out by the Bidders, clause by Clause in this schedule. **Unless** specifically mentioned in this Schedule, the tender shall be deemed to confirm the purchaser's specifications:

Sl. No.	Clause No.	Details of deviation with justifications

We confirm that there are no deviations apart from those detailed above

Seal of the Company:

Signature

Designation

**Indicative GA Drawing of 11kV Metering Cubicle**

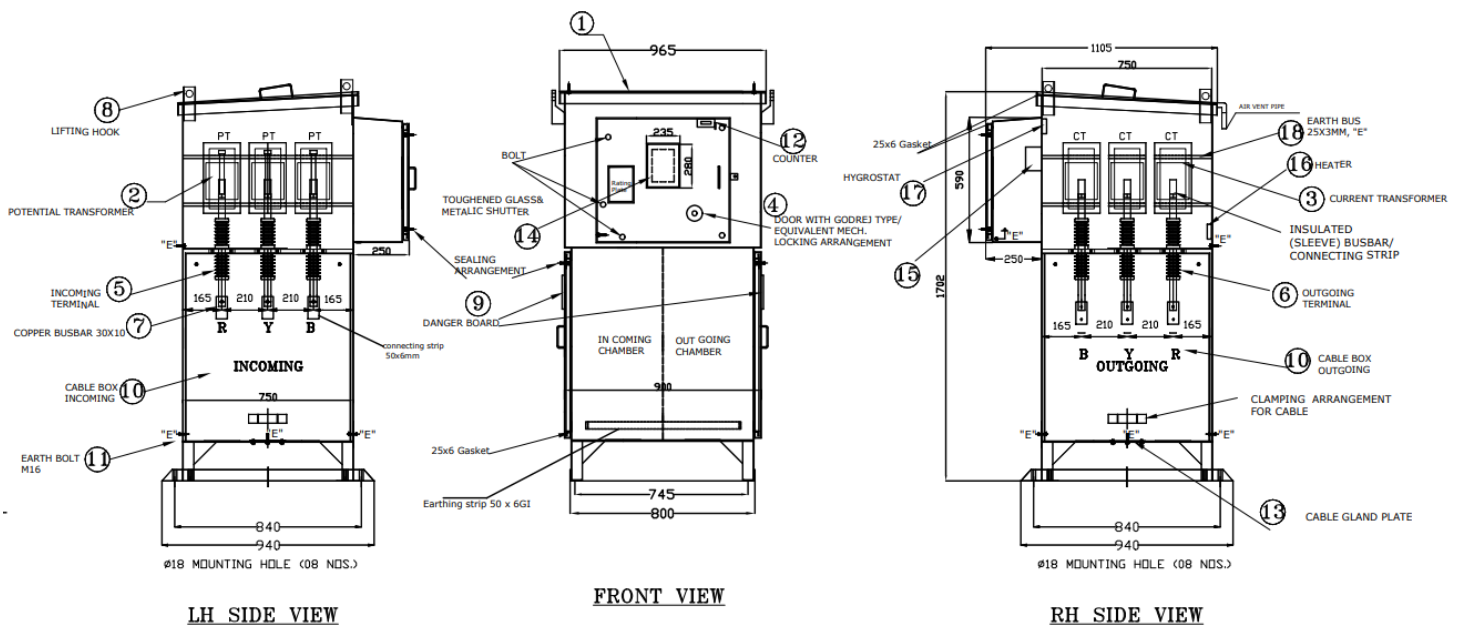

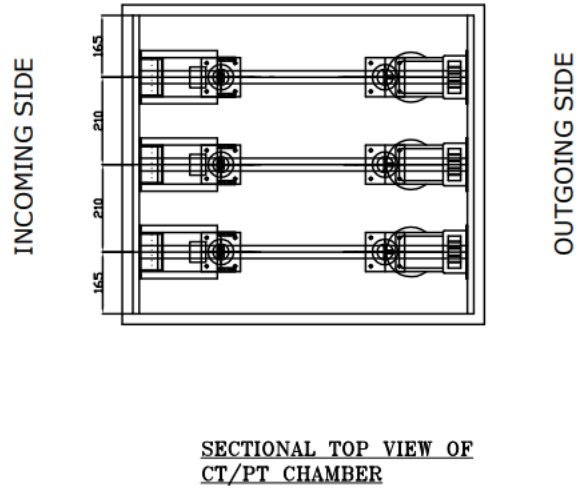
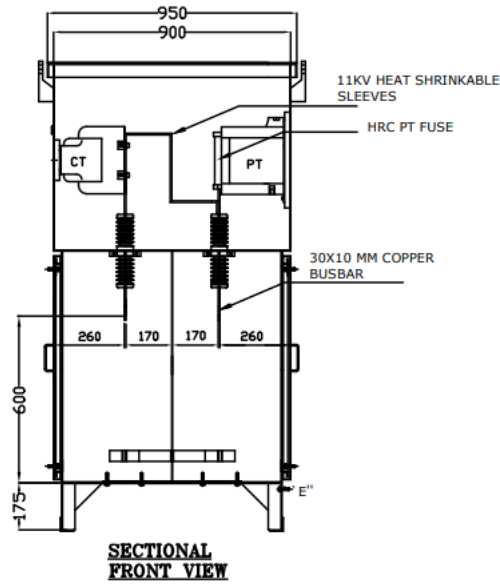

**Note:-**

- If Bidder have Type Tested Design complying all technical parameters of this specification other than above GA drawing that will be accepted
- Bidder should submit all type test reports as per this specification

METERING CUBICLE:		
Sr. No.	Particulars	Parameters
1	Normal system voltage (kV r.m.s)	11
2	Highest system voltage (kV r.m.s)	12
3	Frequency	50HZ
4	Number of Phases	3
5	Impulse withstand voltage (KVpeak) (on assembled CT-PT set)	75 KVpeak
6	Power frequency dry withstand test on (a) primary winding (b) secondary winding	28kV (rms) 3kV (rms)
7	Maximum temperature rise over maximum ambient temperature of 45 <sup>0</sup> C at rated continuous thermal current at rated frequency and with rated burden.	110 <sup>0</sup> C (As per IS 16227-1 for Class F Insulation)
8	Cable connection terminal of CT to base plate distance	750mm Minimum
9	Paint (Powder Coating)	RAL 7032
10	Powder Coating Thickness	80 microns
11	Rating/Size of Bus Bar	Tinned Electrolytic Copper Bus Bar size suitable for all rating of metering cubicle shall be 400A
11.a	Maximum Current Density of Copper Bus Bar	1.75 A/sqmm
12	Enclosure	
a.	Material and thickness of the meter box	3mm GI Sheet with Powder Coating, min. thickness of powder coating shall be 80micron. The paint should sustain for harsh environment & saline weather, Corrosion Protection for Panel entire life cycle (minimum 10 yrs).
b.	Non-current carrying nuts, bolts, screws etc. on enclosure	SS 304
c.	Protection against penetration of dust and water	IP 55
d.	Door of metering compartment	Wire Mess & Door of metering compartment
e.	Size of Enclosure (max. allowed)	1700mm (Height) X 1000mm (Length) X 1200mm (Depth) and suitable to inhouse upto CTR 400/5A
f.	Outdoor Application, if required	Suitable Canopy will be provided in outdoor application, so that meters can be viewed properly

g.	System Earthing	Suitable for 25kA/1sec
h.	Size of Earth Bus Bar	25x3mm Copper (This copper bus to be connected to both side M16 Earth Bolt)
i.	Washers and connectors	Bi-metallic washer and tinned copper connector
j.	Cable cleat	HDPE/Nylon Fire retardant cable cleat
k.	Incoming & Outgoing Cable Cleating Arrangement	Suitable for 3Cx400 sqmm & 1Cx400 sqmm (Actual size of cable to be provided during drawing approval stage)

CURRENT TRANSFORMERS:		
Sr. No.	Particulars	Parameters
1	Normal system voltage (kV r.m.s)	11
2	Highest system voltage (kV r.m.s)	12
3	Frequency	50HZ
4	Type	Single Phase Indoor Resin Cast
5	Number of CT	3Nos
6	Rated output (VA burden)	10VA.
7	Rated continuous thermal current	1.2 times of rated primary current
8	Short time current rating for 1 sec.	<ul style="list-style-type: none"> <li>• 30/5A CT Ratio to 75/5A CT Ratio – 13.1kA/1sec</li> <li>• 100/5 CT Ratio upto 400/5A - 25kA/1sec</li> </ul>
9	Rated dynamic current (Peak)	2.5 times of short time thermal current rating
10	Instrument security factor	≤ 5
11	Impulse withstand voltage (KVpeak) (on assembled CT-PT set)	75 KVpeak
12	Maximum temperature rise over maximum ambient temperature of 45 <sup>0</sup> C at rated continuous thermal current at rated frequency and with rated burden.	110 <sup>0</sup> C (As per IS 16227-1 for Class F Insulation)
13	Type of Insulation	
13.a	Impregnation	Class H vacuum pressure impregnation
13.b	Varnish on CT-PT windings	Class H varnish
13.c	Epoxy resin casting	Class F Resin
14	Limits of current (ratio) Error and phase Displacement. (For 0.2S Accuracy class)	Within limited of IS:16227 with latest amendment/revision

15	Max. ratio error	Within limited of IS:16227 with latest amendment/revision
16	Max. phase angle error	Within limited of IS:16227 with latest amendment/revision
17	System condition	Effectively earthed system
18	Thickness of base plate	5mm, Plate shall be properly with earthing arrangement
19	Type	Dry type epoxy resin cast
20	Creepage distance	300mm (It is only applicable for Insulator connecting for CT, PT & Cable Compartment, if used)
21	Transformation ratio/ CT ratio	As per above schedule of requirement.
22	No. of cores	1 Nos
23	Rated continuous thermal current temperature rise over ambient	As per IS 16227 latest amendment/revision
24	One minute power frequency voltage withstand test on secondary winding	3kV
25	Class of accuracy	0.2S
26	Secondary termination	S1 & S2 shall be clearly marked
27	CT primary current	Shall be as per tender (30A, 50A, 75A, 100A, 150A, 200A, 300A, 400A)
28	CT secondary current	5A
29	Total weight of the core before casting of Resin	To be provided by Bidder
30	Total weight of the unit after casting of Resin	To be provided by Bidder
31	Power frequency dry withstand test on (a) primary winding (b) secondary winding	28kV (rms) 3kV (rms)
32	Washers and connectors	Bi-metallic washer and tinned copper connector
33	CT terminal shape	L-shaped or cross flat type
34	Rating/Size of Bus Bar	Tinned Electrolytic Copper Bus Bar size suitable for all rating of metering cubicle shall be 400A

#### POTENTIAL TRANSFORMERS:

Sr. No.	Particulars	Parameters
1	Normal system voltage (kV r.m.s)	11
2	Highest system voltage (kV r.m.s)	12
3	Frequency	50HZ

4	Type	Single Phase Indoor Resin Cast
5	Number of phases	Single phase
6	No of PT	3 Nos
7	Rated Output (VA) Burden	30VA
8	Transformation ratio (PT ratio)	11KV/ $\sqrt{3}$ / 110V/ $\sqrt{3}$
9	Impulse withstand voltage (KV peak) (on assembled CT PT set)	75
10	One minute power frequency dry withstand voltage (on assembled CT-PT set) (a) Primary (KV rms) (b) Secondary (KV rms)	28kV 3kV
11	Class of accuracy	0.2
12	Rated voltage factor and time	1.2 times continuous and 1.5 times for 30 sec
17	System condition	Effectively earthed system
18	Maximum temperature raise over maximum ambient temperature (which may be taken as 45 <sup>0</sup> C) at rated frequency and with rated Burden	Within limited of IS 16227 with latest amendment/ revision.
19	Maximum ratio error	Within limited of IS 16227 with latest amendment/ revision.
20	Maximum phase angle error	Within limited of IS 16227 with latest amendment/ revision.
21	Type of Insulation	
21.a	Impregnation	Class H vacuum pressure impregnation
21.b	Varnish on CT-PT windings	Class H varnish
21.c	Epoxy resin casting	Class F Resin
22	Creepage distance	300mm (It is only applicable for Insulator connecting for CT, PT & Cable Compartment, if used)
21	Basic insulation Level	12/28/75 KV
22	Thickness of baseplate	5mm, Plate shall be properly with earthing arrangement.
23	Material of Bushings	Epoxy
24	Material for Rod of Bushings	Copper (if applicable)

**Checklist for Bidder : List of all Technical Documents to be submitted along with the bid**  
(Bidder has to mandatorily fill in the checklist mentioned below) :-

Sl.No.	Parameter	Requirement	Response from bidder (with annexure no. with page no.)
1	Bidder has to provide signed & stamped complete Tender Documents along with NIL Deviations undertaking on the tender documents.	Signed and stamped PDF file	
2	Bidder has to provide signed & stamped Approved Pre-bid response as an unconditional acceptance, that there is no deviations in pre-bid response.	Signed and stamped PDF file	
3	Bidder has to submit all the relevant Type test certificates as per tender technical specification along with the bidding documents.	Detailed Requirements to be filled in as per TP Odisha DISCOMs Standard <b>Table No 2.</b>	
4	Bidder has to submit all GTP parameters in Excel Format along with the bid as per Technical specification.	Detailed Requirements to be filled in as per TP Odisha DISCOMs Standard <b>Table No 3.</b>	
5	Bidder has to submit declaration for Manufacturing & Testing facilities available in his premises for the routine & acceptance tests mentioned in the technical specification. Bidder has to mention all manufacturing & testing facilities against each tests mentioned in the routine & acceptance tests in the technical specification (duly mentioned on bidder letter head, signed & stamped).	Undertaking along with detailed requirements to be filled in as per TP Odisha DISCOMs Standard <b>Table No 4.</b>	
6	Bidders has to submit prototype product along with the bid documents for evaluation as per the Technical Specification.	To be provided, if mentioned in the technical specification or in pre-bid response.	
7	Incase the type tests are done with NABL accredited Labs bidder has to submit the details of scope of accreditation from NABL.	To be provided	
8	Bidder has to provide mandatorily the Past Performance Certificate issued from distribution utility companies, relevant certificates from other companies can be submitted along with the utility performance certificates.	Signed and stamped PDF file. In this document bidder is requested to provide contact details(mobile no. & Email I'd) of the issuing company.	

**Table No. 2: Details of Type Test Reports as per Specification/ Relevant Standards**

Sl. No.	Name of Type Test	Reference Standard	Date of issuance of report with Result Pass/ Fail	Name of Lab

**Note** All the type test report must be submitted with Bid Documents only, otherwise Bid may not be consider for evaluation. Further if, undertaking for type test to be submitted, the Undertaking should be on Letter Head of Organisation and with sign, full name & designation of Head of Function (like Head Quality, Engineering etc). This also include the name of type test to be conducted with timeline. Acceptance or Rejection of Undertaking shall be sole decision of TP Odisha Discom.

**Table No. 3: Details of GTP to be filled**

Sl. No.	Technical Parameter	Unit	TP Odisha DISCOMs Requirement	Bidder's Offer

**Table No. 4: Details of Testing facilities available at bidder's premises for carrying out routine & acceptance tests**

Sl. No.	Name of the Test	Reference Standard	Details of the Testing Equipment (Make & Sl. No.)	Validations of the calibration certificate

Name of bidder

Signature of bidder

Date